

Lecture 13:

Generative Models

Administrative

- A3 is out. Due May 28.
- Milestone was due **May 17th (pay attention to the date)**
 - Read website page for milestone requirements.
 - Need to Finish data preprocessing and initial results by then.
- Midterm and A2 grades will be out this week

Supervised vs Unsupervised Learning

Supervised Learning

Data: (x, y)

x is data, y is label

Goal: Learn a function to map $x \rightarrow y$

Examples: Classification, regression, object detection, semantic segmentation, image captioning, etc.

Supervised vs Unsupervised Learning

Supervised Learning

Data: (x, y)

x is data, y is label

Goal: Learn a function to map $x \rightarrow y$

Examples: Classification, regression, object detection, semantic segmentation, image captioning, etc.



→ Cat

Classification

[This image is CC0 public domain](#)

Supervised vs Unsupervised Learning

Supervised Learning

Data: (x, y)

x is data, y is label

Goal: Learn a function to map $x \rightarrow y$

Examples: Classification, regression, object detection, semantic segmentation, image captioning, etc.



A cat sitting on a suitcase on the floor

Image captioning

Caption generated using [neuraltalk2](#)
Image is [CC0 Public domain](#)

Supervised vs Unsupervised Learning

Supervised Learning

Data: (x, y)

x is data, y is label

Goal: Learn a function to map $x \rightarrow y$

Examples: Classification, regression, object detection, semantic segmentation, image captioning, etc.

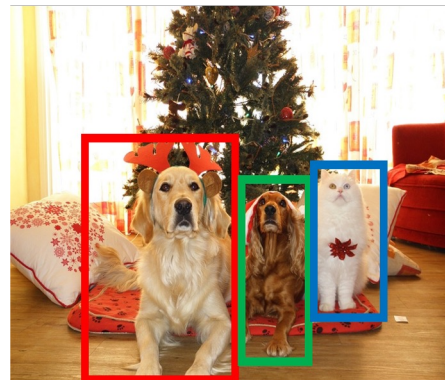

DOG, DOG, CAT

Object Detection

[This image is CC0 public domain](#)

Supervised vs Unsupervised Learning

Supervised Learning

Data: (x, y)

x is data, y is label

Goal: Learn a function to map $x \rightarrow y$

Examples: Classification, regression, object detection, semantic segmentation, image captioning, etc.

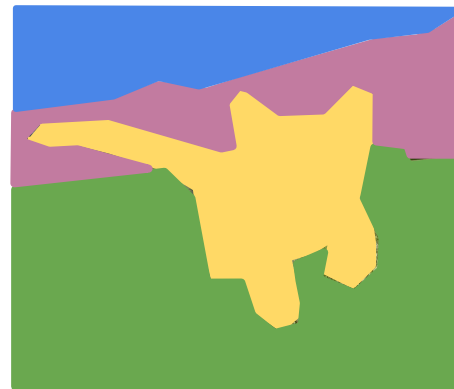

GRASS, CAT, TREE,
SKY

Semantic Segmentation

Supervised vs Unsupervised Learning

Unsupervised Learning

Data: x

Just data, no labels!

Goal: Learn some underlying hidden structure of the data

Examples: Clustering, dimensionality reduction, density estimation, etc.

Supervised vs Unsupervised Learning

Unsupervised Learning

Data: x

Just data, no labels!

Goal: Learn some underlying hidden structure of the data

Examples: Clustering, dimensionality reduction, density estimation, etc.

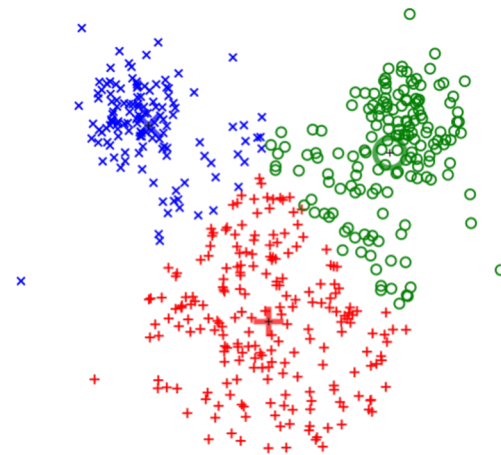

K-means clustering

[This image is CC0 public domain](#)

Supervised vs Unsupervised Learning

Unsupervised Learning

Data: X

Just data, no labels!

Goal: Learn some underlying hidden structure of the data

Examples: Clustering, dimensionality reduction, density estimation, etc.

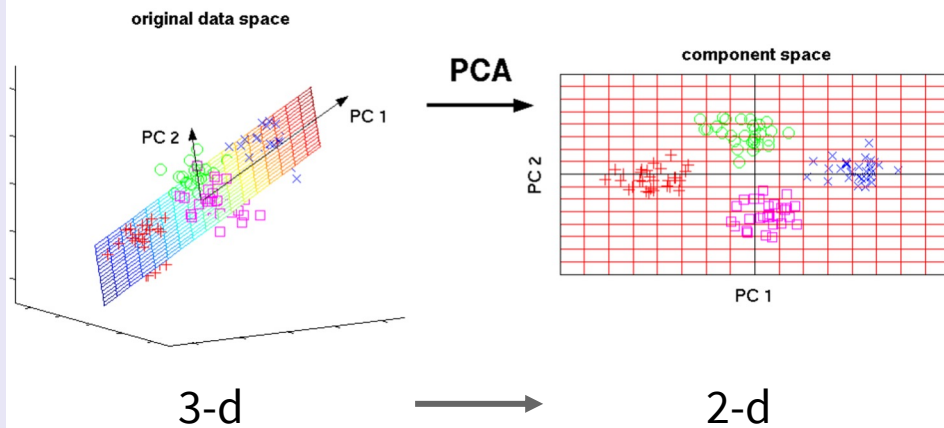

Principal Component Analysis
(Dimensionality reduction)

[This image](#) from Matthias Scholz is
[CC0 public domain](#)

Supervised vs Unsupervised Learning

Unsupervised Learning

Data: x

Just data, no labels!

Goal: Learn some underlying hidden structure of the data

Examples: Clustering, dimensionality reduction, density estimation, etc.

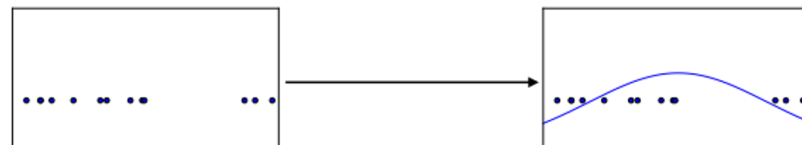
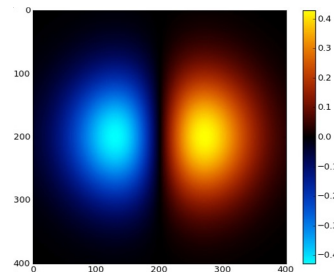
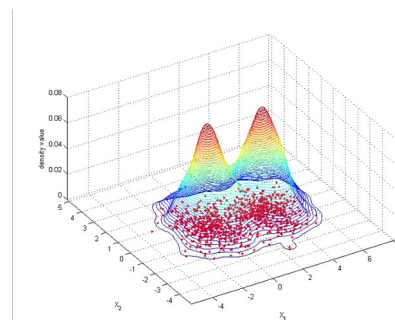

Figure copyright Ian Goodfellow, 2016. Reproduced with permission.

1-d density estimation



2-d density estimation

Modeling $p(x)$

2-d density images [left](#) and [right](#) are [CC0 public domain](#)

Supervised vs Unsupervised Learning

Supervised Learning

Data: (x, y)

x is data, y is label

Goal: Learn a function to map $x \rightarrow y$

Examples: Classification, regression, object detection, semantic segmentation, image captioning, etc.

Unsupervised Learning

Data: x

Just data, no labels!

Goal: Learn some underlying hidden structure of the data

Examples: Clustering, dimensionality reduction, density estimation, etc.

Supervised vs Unsupervised Learning

Supervised Learning

Data: (x, y)

x is data, y is label

Goal: Learn a function to map
 $x \rightarrow y$

Examples: Classification, regression, object detection, semantic segmentation, image captioning, etc.

Unsupervised Learning

Data: x

Just data, no labels!

Goal: Learn some underlying hidden structure of the data

Examples: Clustering, dimensionality reduction, density estimation, etc.

Self-Supervised Learning

Data: $(x, \text{pseudo generated } y)$

No manual labels!

Goal: Learn to generate good features (reduce the data to useful/generic features)

Example: Classification in downstream applications where we have limited data

Generative Modeling

Given training data, generate new samples from same distribution

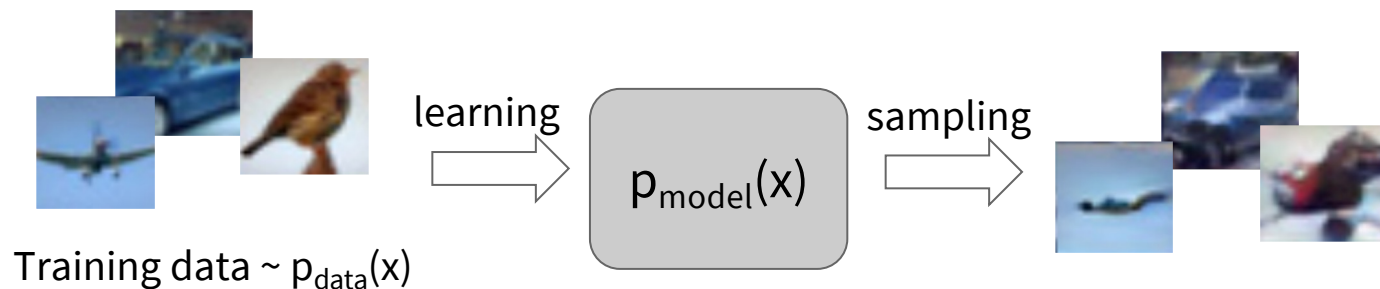

Objectives:

1. Learn $p_{\text{model}}(x)$ that approximates $p_{\text{data}}(x)$
2. Sampling new x from $p_{\text{model}}(x)$

Generative Modeling

Given training data, generate new samples from same distribution

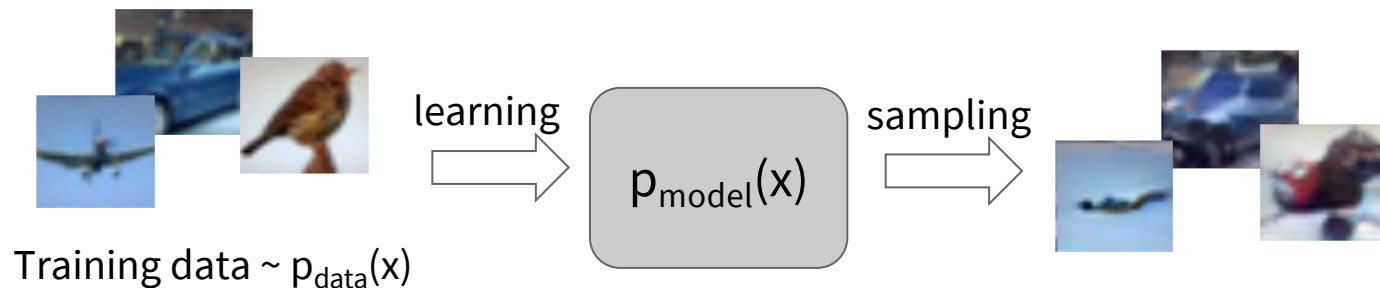

Formulate as density estimation problems:

- Explicit density estimation: explicitly define and solve for $p_{\text{model}}(x)$
- Implicit density estimation: learn model that can sample from $p_{\text{model}}(x)$ without explicitly defining it.

Why Generative Models?



- Realistic samples for artwork, super-resolution, colorization, etc.
- Learn useful features for downstream tasks such as classification.
- Getting insights from high-dimensional data (physics, medical imaging, etc.)
- Modeling physical world for simulation and planning (robotics and reinforcement learning applications)
- Many more ...

Figures from L-R are copyright: (1) [Alec Radford et al. 2016](#); (2) [Phillip Isola et al. 2017](#). Reproduced with authors permission (3) [BAIR Blog](#).

Taxonomy of Generative Models

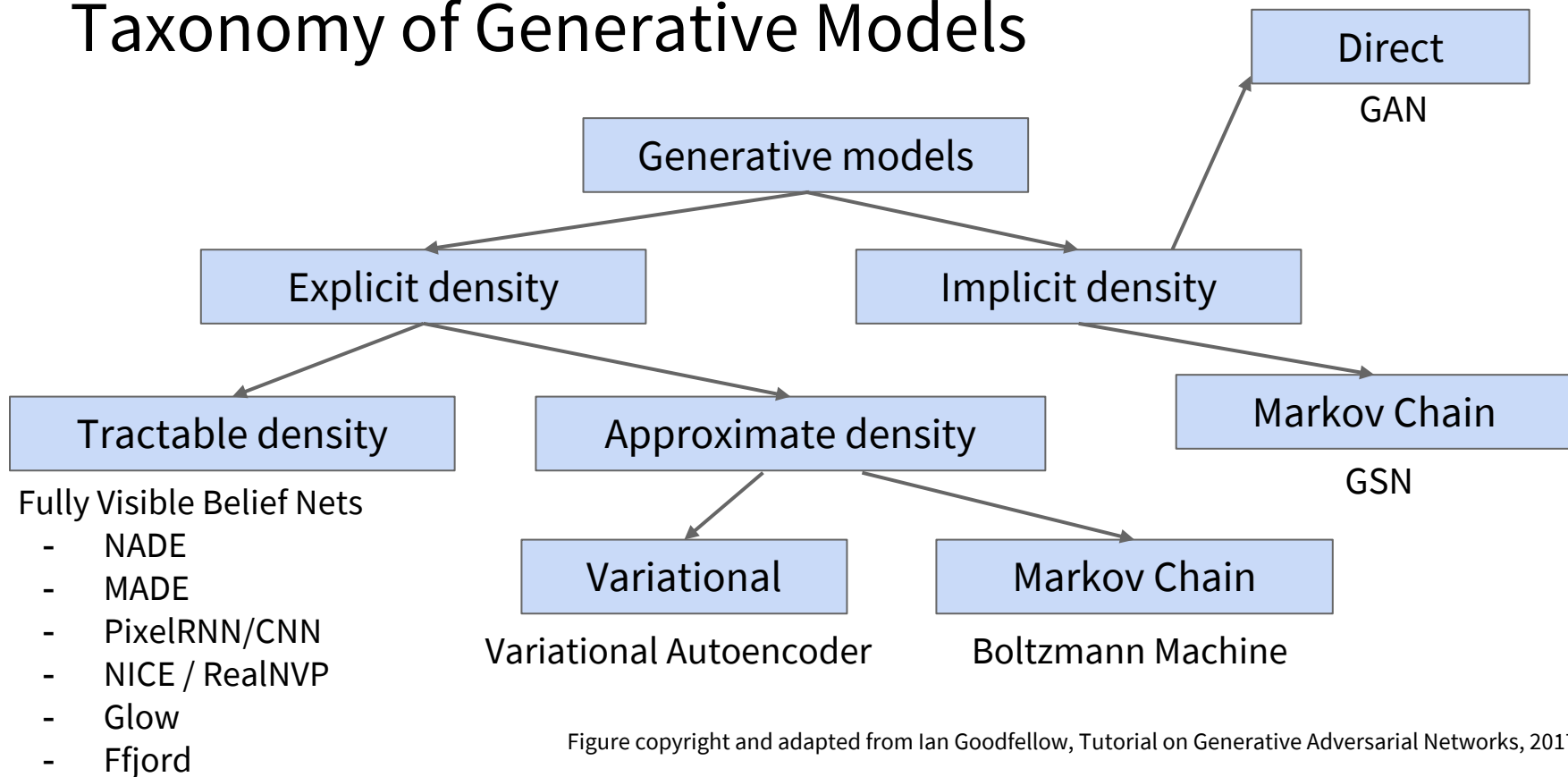

Figure copyright and adapted from Ian Goodfellow, Tutorial on Generative Adversarial Networks, 2017.

Taxonomy of Generative Models

Today: discuss 3 most popular types of generative models today

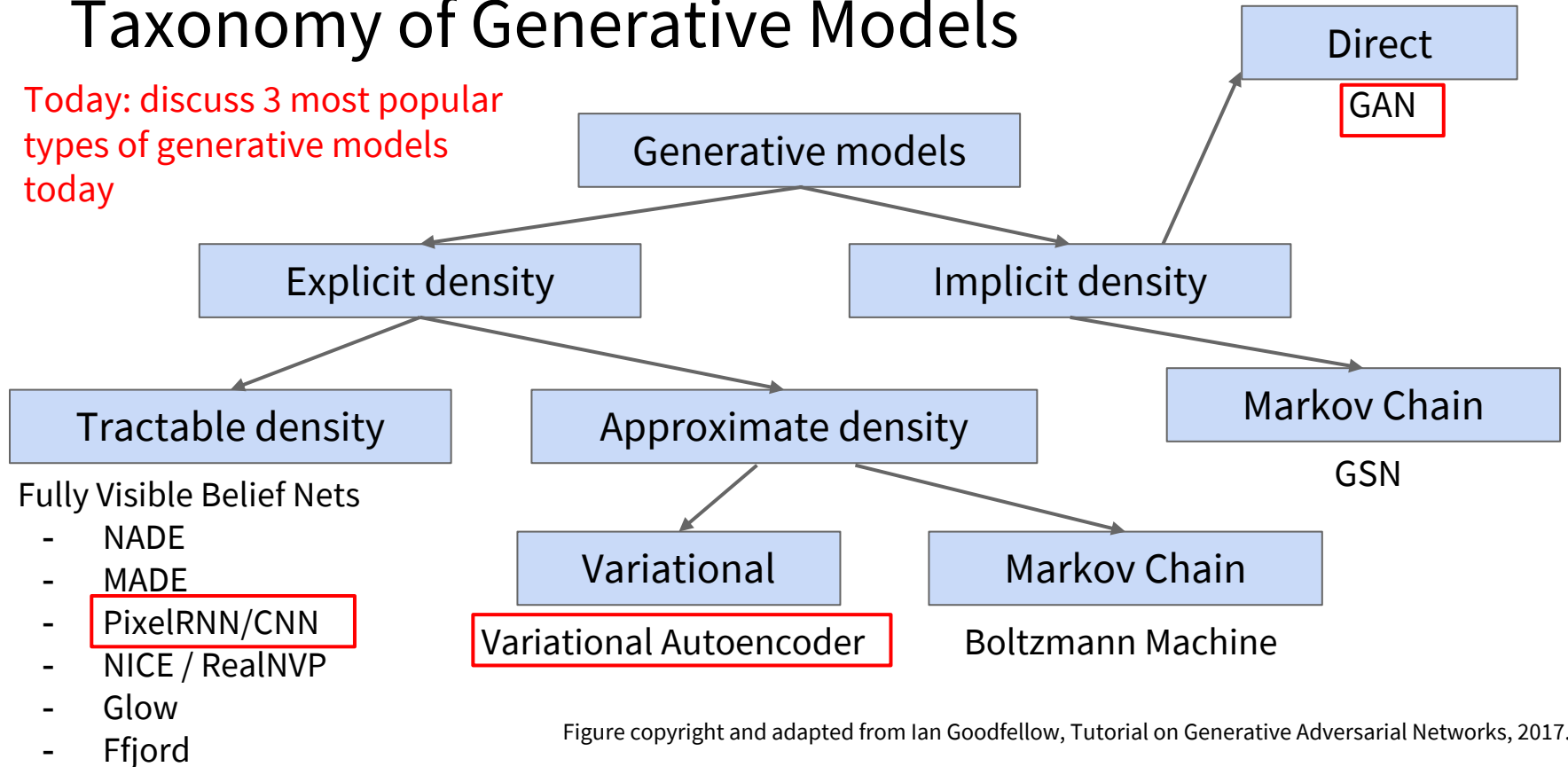

Figure copyright and adapted from Ian Goodfellow, Tutorial on Generative Adversarial Networks, 2017.

PixelRNN and PixelCNN

(A very brief overview)

Fully visible belief network (FVBN)

Explicit density model

$$p(x) = p(x_1, x_2, \dots, x_n)$$

↑
Likelihood of
image x

↑
Joint likelihood of each
pixel in the image

Recurrent Neural Network

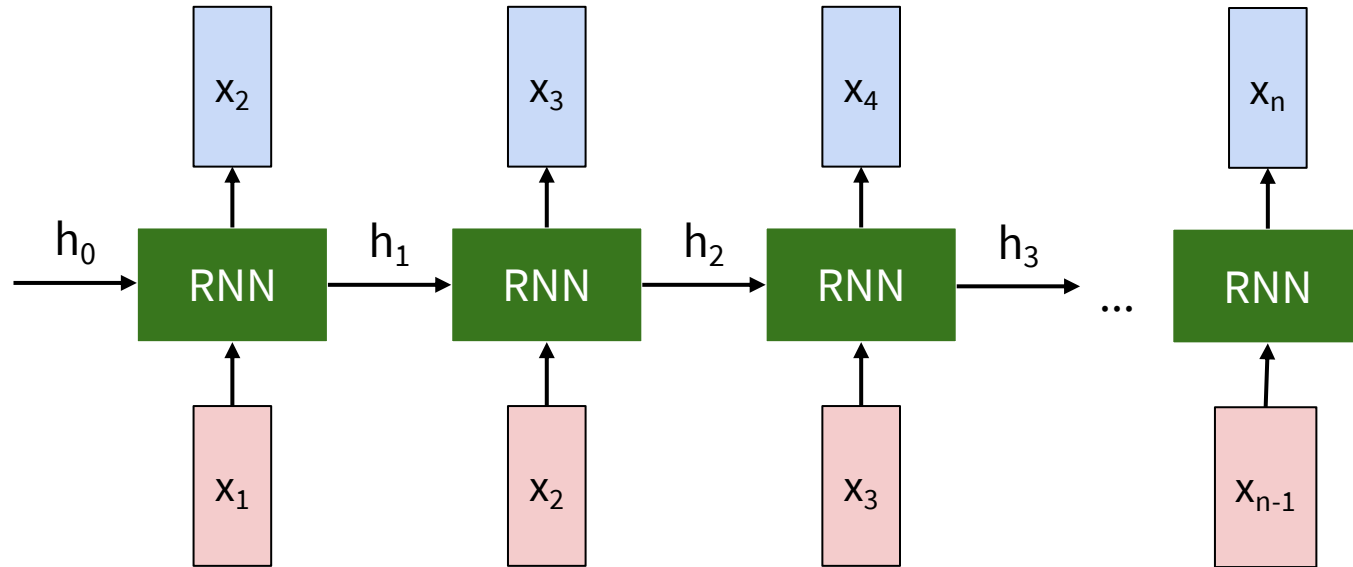

$$p(x_i | x_1, \dots, x_{i-1})$$

PixelRNN [van der Oord et al. 2016]

Generate image pixels starting from corner

Dependency on previous pixels modeled using an RNN (LSTM)

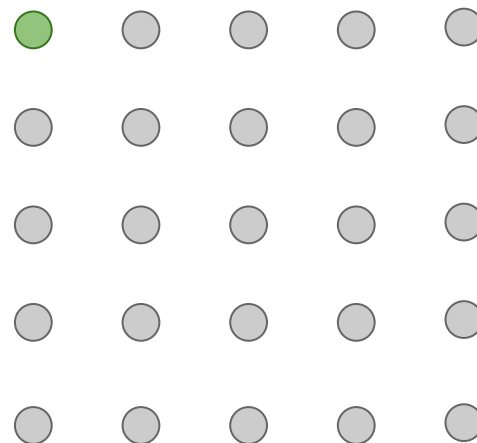

PixelRNN [van der Oord et al. 2016]

Generate image pixels starting from corner

Dependency on previous pixels modeled using an RNN (LSTM)

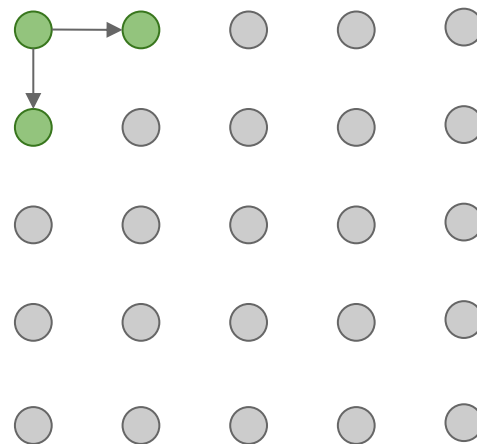

PixelRNN [van der Oord et al. 2016]

Generate image pixels starting from corner

Dependency on previous pixels modeled using an RNN (LSTM)

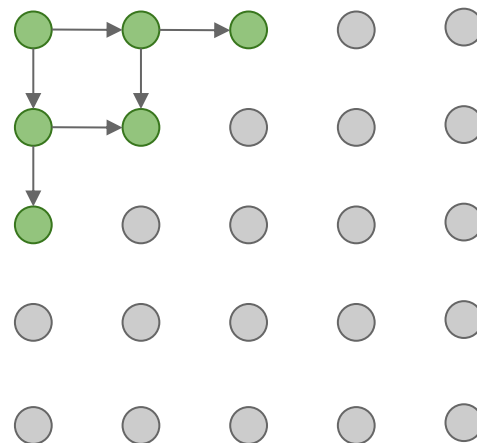

PixelRNN [van der Oord et al. 2016]

Generate image pixels starting from corner

Dependency on previous pixels modeled using an RNN (LSTM)

Drawback: sequential generation is slow in both training and inference!

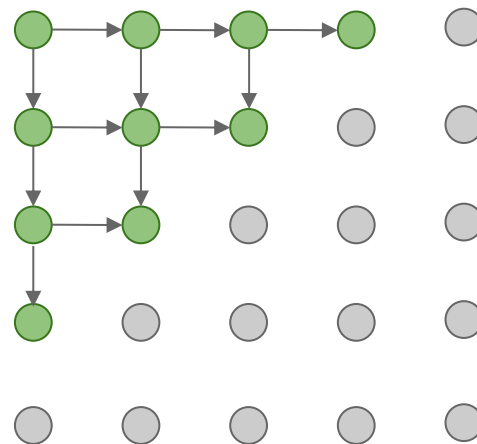

PixelCNN [van der Oord et al. 2016]

Still generate image pixels starting from corner

Dependency on previous pixels now modeled using a CNN over context region (masked convolution)

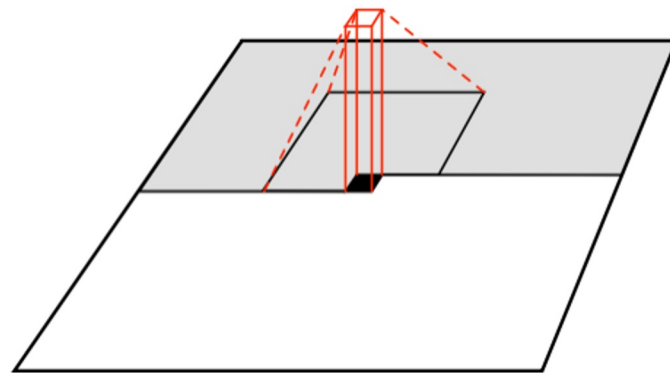

Figure copyright van der Oord et al., 2016. Reproduced with permission.

PixelCNN [van der Oord et al. 2016]

Still generate image pixels starting from corner

Dependency on previous pixels now modeled using a CNN over context region (masked convolution)

Training is faster than PixelRNN (can parallelize convolutions since context region values known from training images)

Generation is still slow:
For a 32x32 image, we need to do forward passes of the network 1024 times for a single image

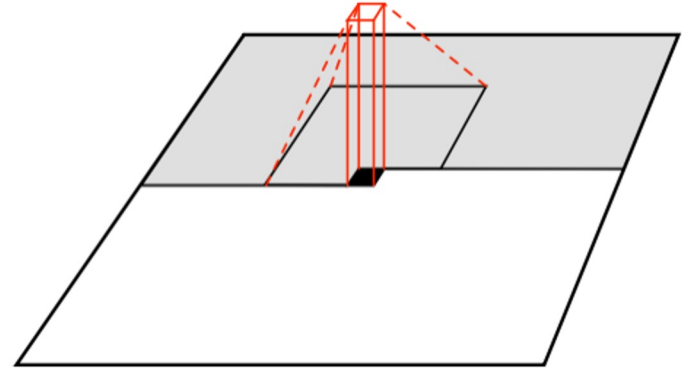
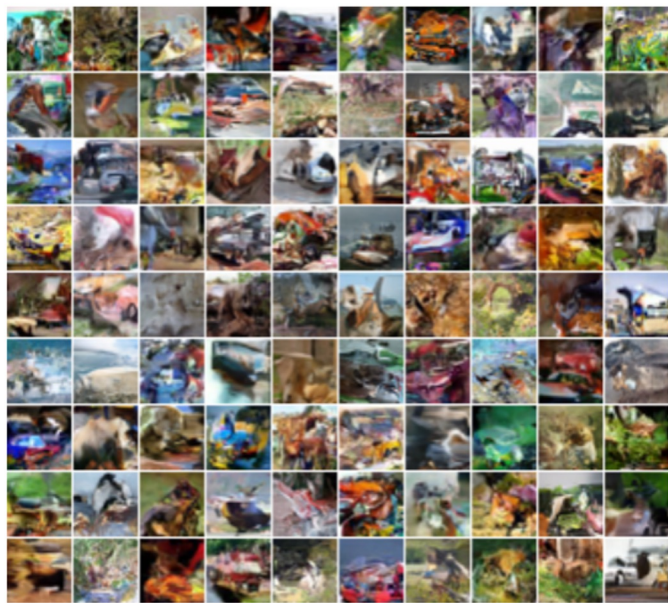
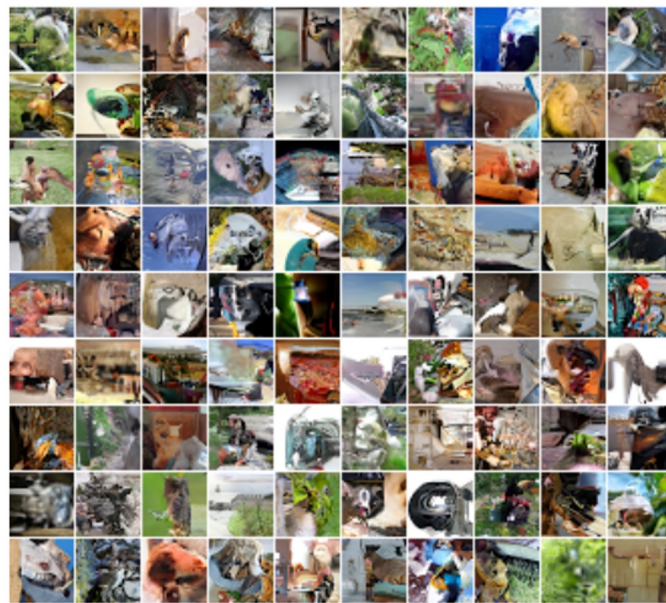

Figure copyright van der Oord et al., 2016. Reproduced with permission.

Generation Samples



32x32 CIFAR-10



32x32 ImageNet

Figures copyright Aaron van der Oord et al., 2016. Reproduced with permission.

PixelRNN and PixelCNN

Pros:

- Can explicitly compute likelihood $p(x)$
- Easy to optimize
- Good samples

Con:

- Sequential generation => slow

Improving PixelCNN performance

- Gated convolutional layers
- Short-cut connections
- Discretized logistic loss
- Multi-scale
- Training tricks
- Etc...

See

- Van der Oord et al. NIPS 2016
- Salimans et al. 2017 (PixelCNN++)

Taxonomy of Generative Models

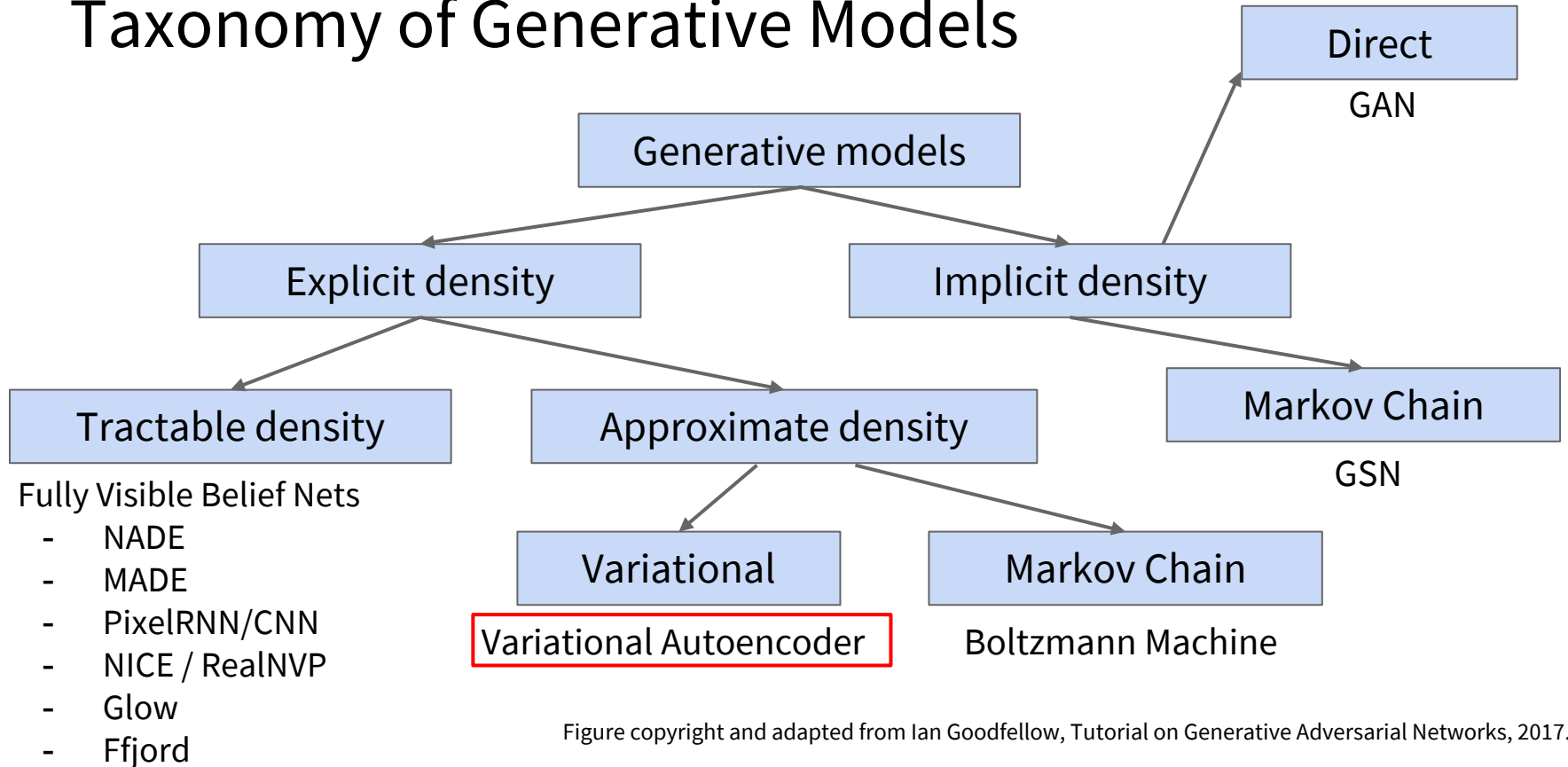

Figure copyright and adapted from Ian Goodfellow, Tutorial on Generative Adversarial Networks, 2017.

Variational Autoencoders (VAE)

So far...

PixelRNN/CNNs define tractable density function, optimize likelihood of training data:

$$p_{\theta}(x) = \prod_{i=1}^n p_{\theta}(x_i | x_1, \dots, x_{i-1})$$

So far...

PixelRNN/CNNs define tractable density function, optimize likelihood of training data:

$$p_{\theta}(x) = \prod_{i=1}^n p_{\theta}(x_i | x_1, \dots, x_{i-1})$$

Variational Autoencoders (VAEs) define intractable density function with latent z :

$$p_{\theta}(x) = \int p_{\theta}(z) p_{\theta}(x|z) dz$$

No dependencies among pixels, can generate all pixels at the same time!

Cannot optimize directly, derive and optimize lower bound on likelihood instead

So far...

PixelRNN/CNNs define tractable density function, optimize likelihood of training data:

$$p_{\theta}(x) = \prod_{i=1}^n p_{\theta}(x_i | x_1, \dots, x_{i-1})$$

Variational Autoencoders (VAEs) define intractable density function with latent z :

$$p_{\theta}(x) = \int p_{\theta}(z) p_{\theta}(x|z) dz$$

No dependencies among pixels, can generate all pixels at the same time!

Cannot optimize directly, derive and optimize lower bound on likelihood instead

Why latent z ?

Some background first: Autoencoders

Unsupervised approach for learning a lower-dimensional feature representation from unlabeled training data

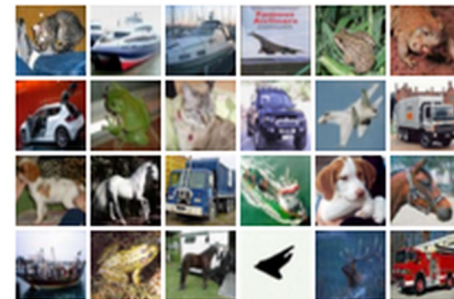
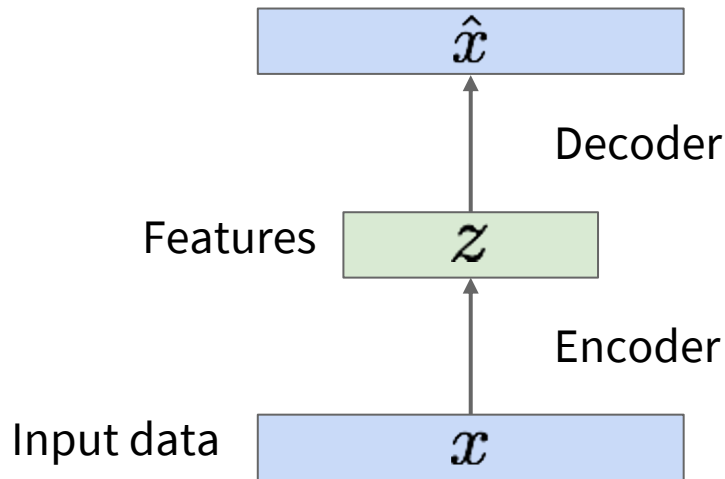

Some background first: Autoencoders

Unsupervised approach for learning a lower-dimensional feature representation from unlabeled training data

z usually smaller than x
(dimensionality reduction)

Q: Why dimensionality reduction?

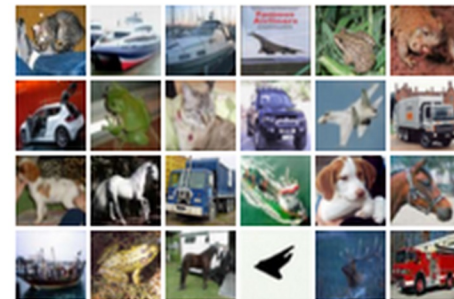
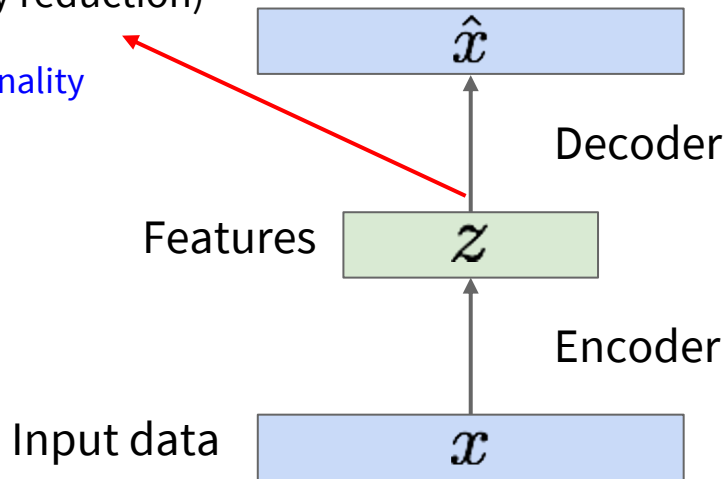

Some background first: Autoencoders

Unsupervised approach for learning a lower-dimensional feature representation from unlabeled training data

z usually smaller than x
(dimensionality reduction)

Q: Why dimensionality reduction?

A: Want features to capture meaningful factors of variation in data

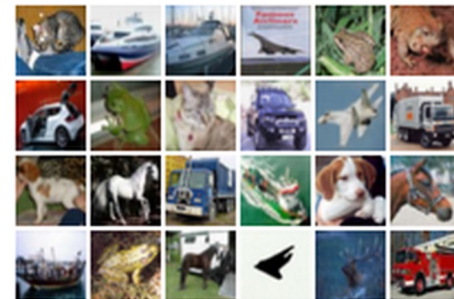
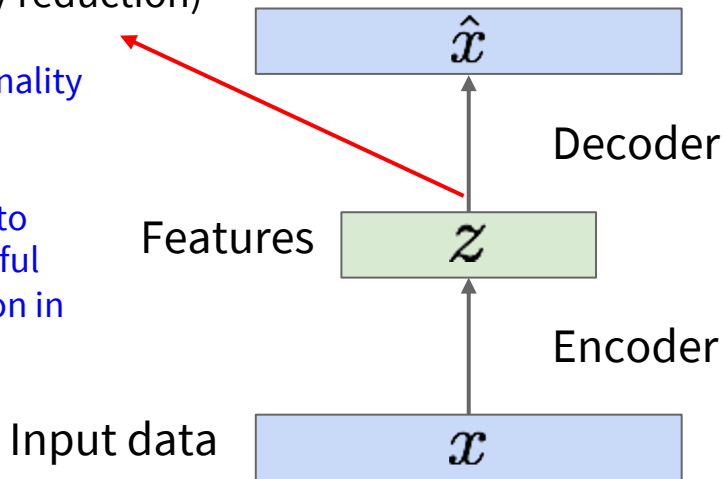

Some background first: Autoencoders

How to learn this feature representation?

Train such that features can be used to reconstruct original data
“Autoencoding” - encoding input itself

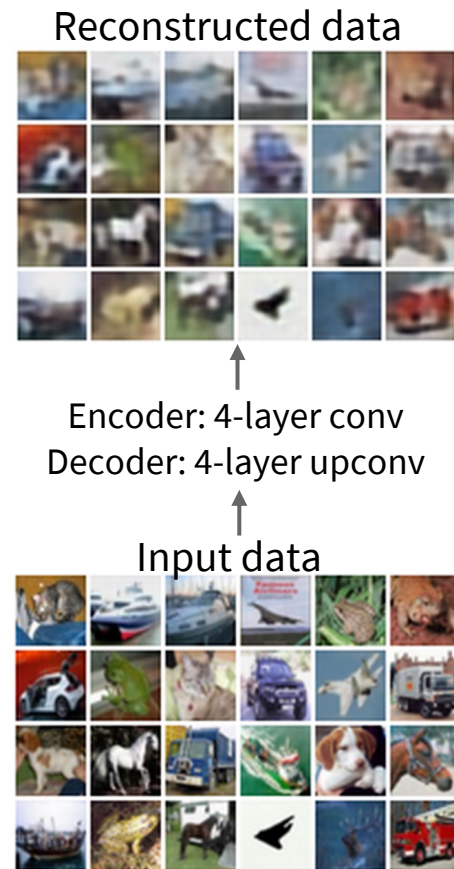
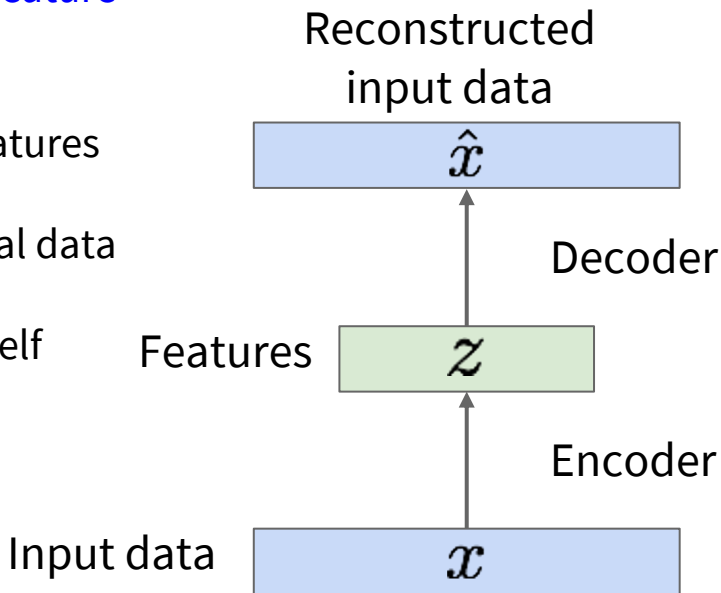

Some background first: Autoencoders

Train such that features can be used to reconstruct original data

Doesn't use labels!

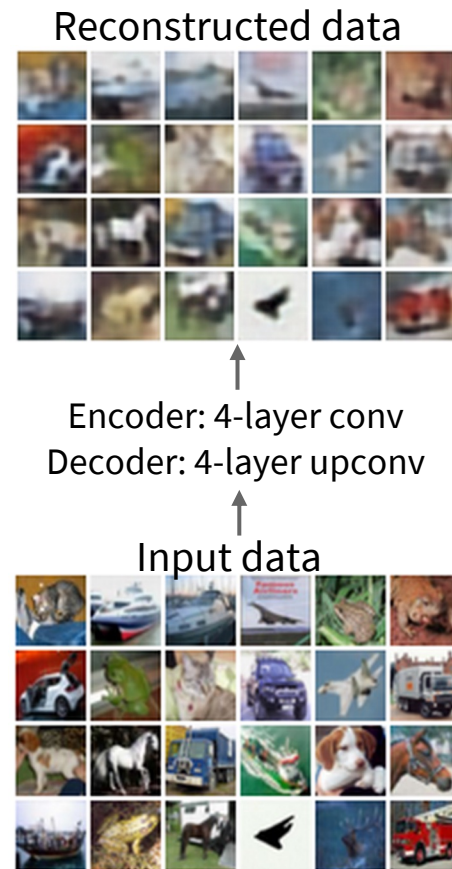
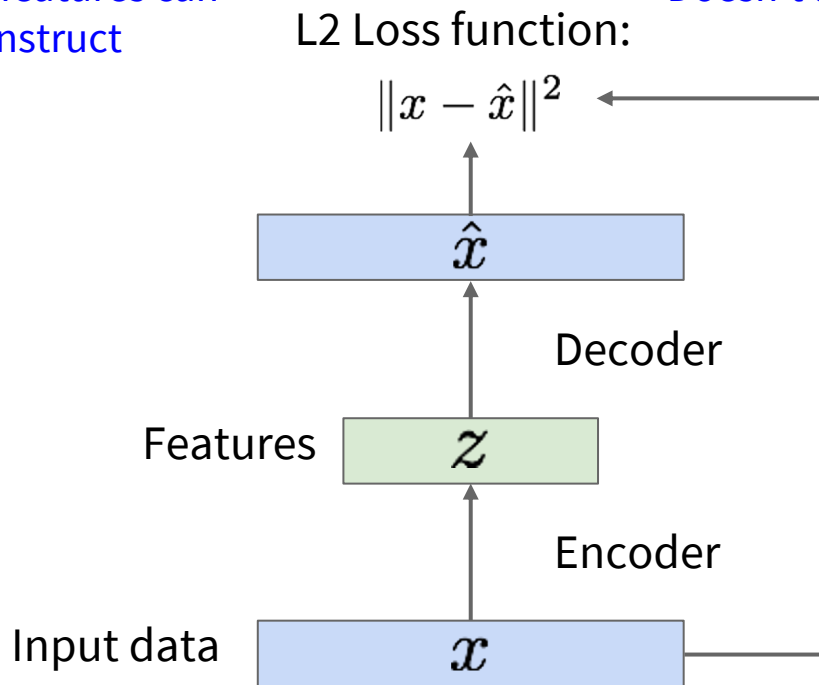

Some background first: Autoencoders

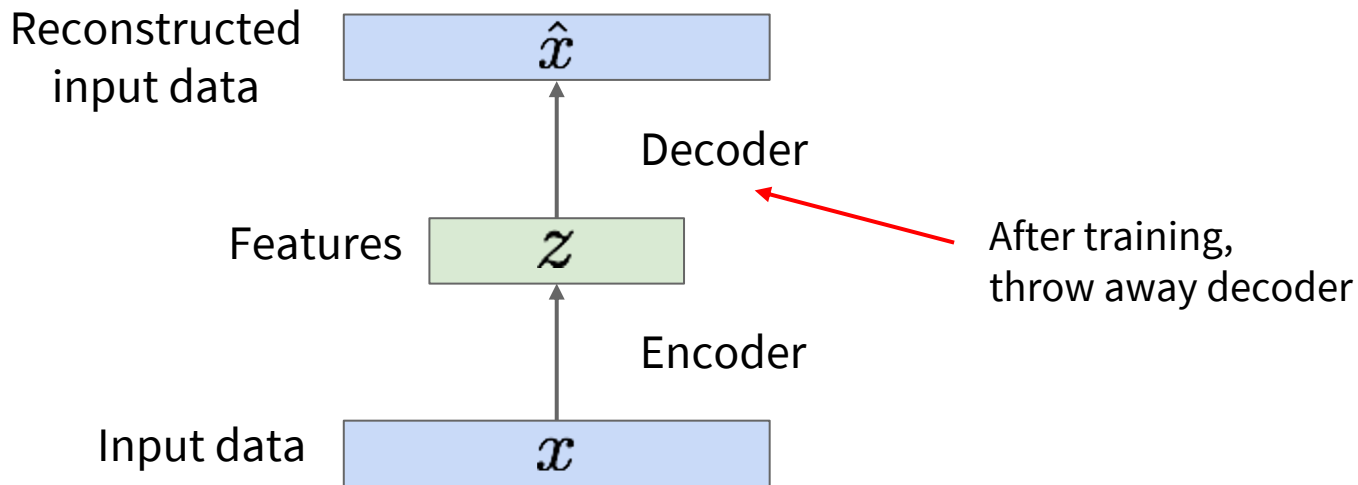

Some background first: Autoencoders

Transfer from large, unlabeled dataset to small, labeled dataset.

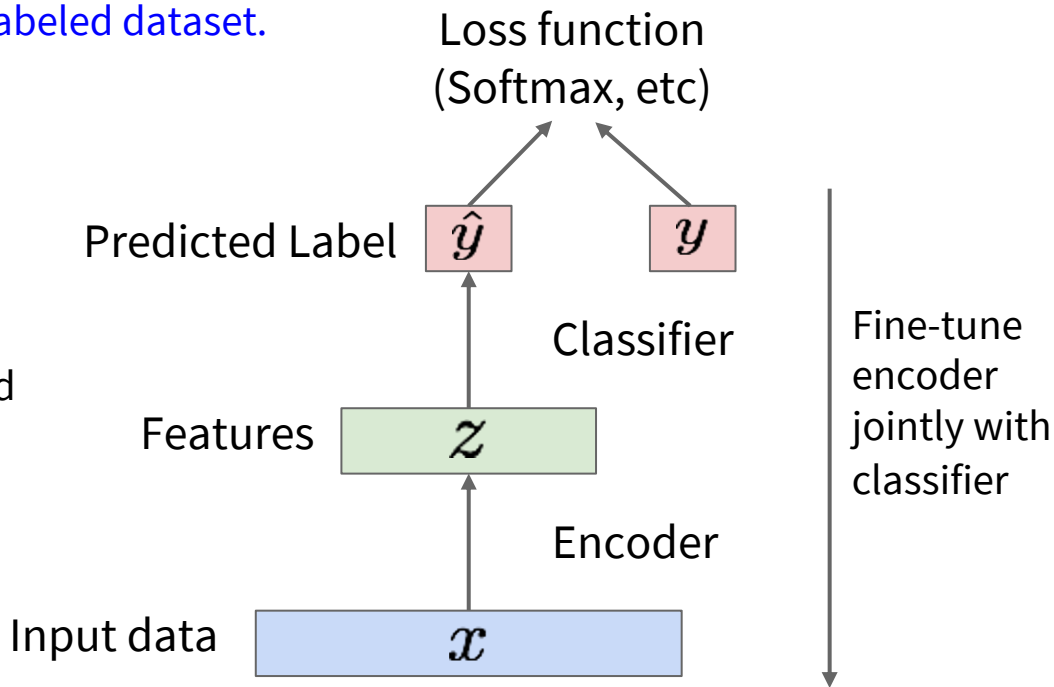

Encoder can be used to initialize a supervised model

bird plane
dog deer truck

Train for final task (sometimes with small data)

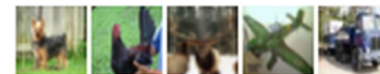

Some background first: Autoencoders

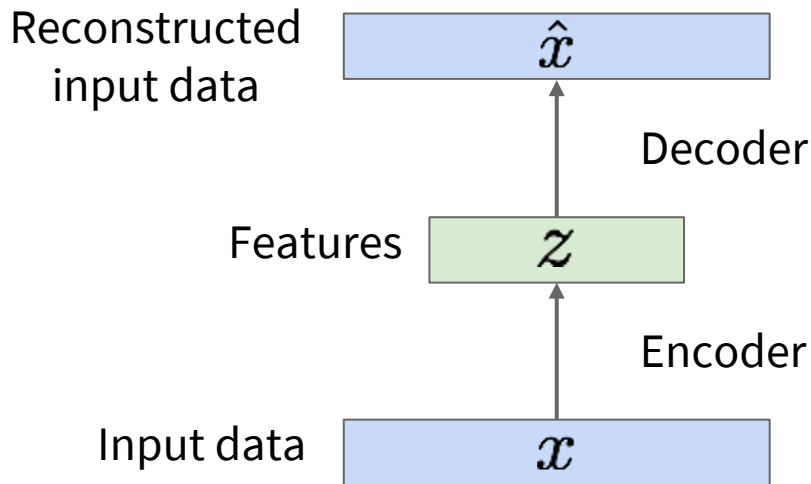

Autoencoders can reconstruct data, and can learn features to initialize a supervised model

Features capture factors of variation in training data.

But we can't generate new images from an autoencoder because we don't know the space of z .

How do we make autoencoder a generative model?

Variational Autoencoders

Probabilistic spin on autoencoders - will let us sample from the model to generate data!

Variational Autoencoders

Probabilistic spin on autoencoders - will let us sample from the model to generate data!

Assume training data $\{x^{(i)}\}_{i=1}^N$ is generated from the distribution of unobserved (latent) representation z

Sample from
true conditional

$$p_{\theta^*}(x | z^{(i)})$$

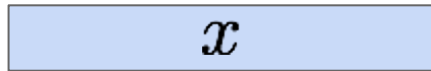

Sample from
true prior

$$z^{(i)} \sim p_{\theta^*}(z)$$

Kingma and Welling, "Auto-Encoding Variational Bayes", ICLR 2014

Variational Autoencoders

Probabilistic spin on autoencoders - will let us sample from the model to generate data!

Assume training data $\{x^{(i)}\}_{i=1}^N$ is generated from the distribution of unobserved (latent) representation z

Sample from
true conditional
 $p_{\theta^*}(x | z^{(i)})$

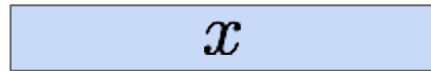

Sample from
true prior
 $z^{(i)} \sim p_{\theta^*}(z)$

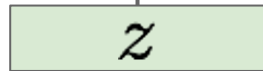

Intuition (remember from autoencoders!): x is an image, z is latent factors used to generate x : attributes, orientation, etc.

Kingma and Welling, "Auto-Encoding Variational Bayes", ICLR 2014

Variational Autoencoders

We want to estimate the true parameters θ^* of this generative model given training data x .

Sample from
true conditional

$$p_{\theta^*}(x | z^{(i)})$$

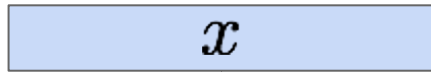

Sample from
true prior

$$z^{(i)} \sim p_{\theta^*}(z)$$

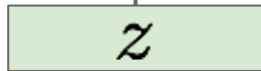

Kingma and Welling, "Auto-Encoding Variational Bayes", ICLR 2014

Variational Autoencoders

We want to estimate the true parameters θ^* of this generative model given training data x .

Sample from
true conditional
 $p_{\theta^*}(x | z^{(i)})$

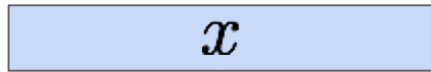

Sample from
true prior
 $z^{(i)} \sim p_{\theta^*}(z)$

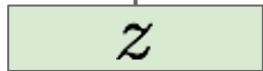

How should we represent this model?

Kingma and Welling, "Auto-Encoding Variational Bayes", ICLR 2014

Variational Autoencoders

Sample from
true conditional

$$p_{\theta^*}(x | z^{(i)})$$

Sample from
true prior

$$z^{(i)} \sim p_{\theta^*}(z)$$

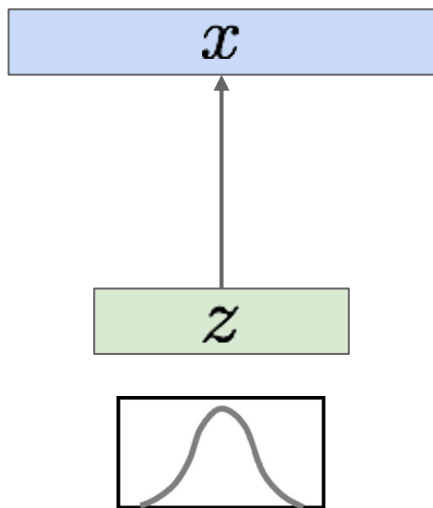

We want to estimate the true parameters θ^* of this generative model given training data x .

How should we represent this model?

Choose prior $p(z)$ to be simple, e.g. Gaussian.
Reasonable for latent attributes, e.g. pose, how much smile.

Kingma and Welling, "Auto-Encoding Variational Bayes", ICLR 2014

Variational Autoencoders



Sample from
true conditional

$$p_{\theta^*}(x | z^{(i)})$$

Sample from
true prior

$$z^{(i)} \sim p_{\theta^*}(z)$$

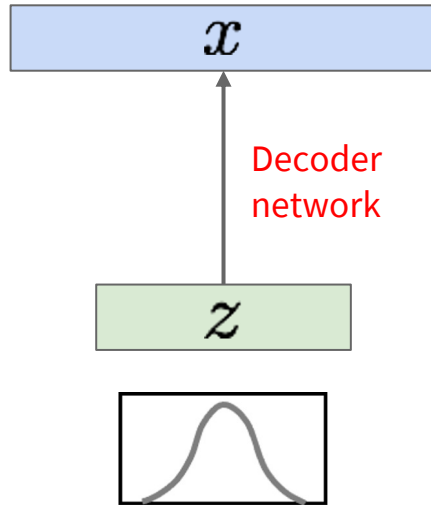

We want to estimate the true parameters θ^* of this generative model given training data x .

How should we represent this model?

Choose prior $p(z)$ to be simple, e.g. Gaussian.
Reasonable for latent attributes, e.g. pose, how much smile.

Conditional $p(x|z)$ is complex (generates image)
=> represent with neural network

Kingma and Welling, “Auto-Encoding Variational Bayes”, ICLR 2014

Variational Autoencoders

We want to estimate the true parameters θ^* of this generative model given training data x .

Sample from true conditional

$$p_{\theta^*}(x | z^{(i)})$$

Sample from true prior

$$z^{(i)} \sim p_{\theta^*}(z)$$

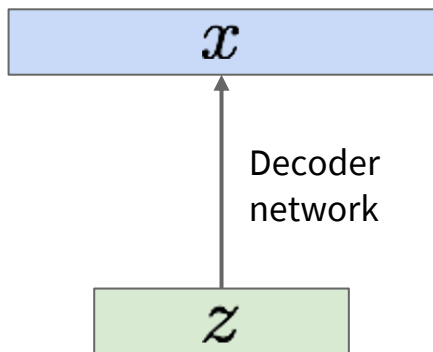

How to train the model?

Kingma and Welling, "Auto-Encoding Variational Bayes", ICLR 2014

Variational Autoencoders

Sample from
true conditional

$$p_{\theta^*}(x | z^{(i)})$$

Sample from
true prior

$$z^{(i)} \sim p_{\theta^*}(z)$$

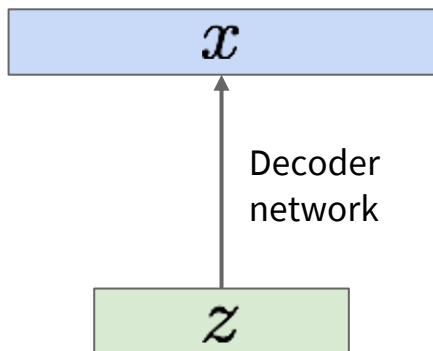

We want to estimate the true parameters θ^* of this generative model given training data x .

How to train the model?

Learn model parameters to maximize likelihood of training data

$$p_{\theta}(x) = \int p_{\theta}(z)p_{\theta}(x|z)dz$$

Kingma and Welling, "Auto-Encoding Variational Bayes", ICLR 2014

Variational Autoencoders

Sample from
true conditional

$$p_{\theta^*}(x | z^{(i)})$$

Sample from
true prior

$$z^{(i)} \sim p_{\theta^*}(z)$$

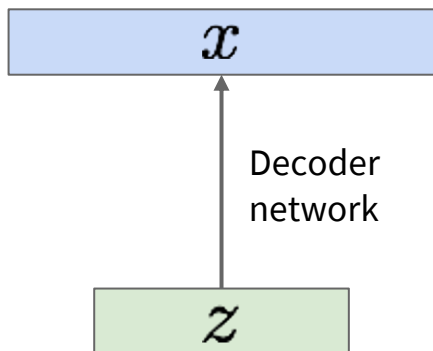

We want to estimate the true parameters θ^* of this generative model given training data x .

How to train the model?

Learn model parameters to maximize likelihood of training data

$$p_{\theta}(x) = \int p_{\theta}(z)p_{\theta}(x|z)dz$$

Q: What is the problem with this?

Intractable!

Kingma and Welling, "Auto-Encoding Variational Bayes", ICLR 2014

Variational Autoencoders: Intractability

Data likelihood: $p_{\theta}(x) = \int p_{\theta}(z)p_{\theta}(x|z)dz$

Kingma and Welling, “Auto-Encoding Variational Bayes”, ICLR 2014

Variational Autoencoders: Intractability

Data likelihood: $p_{\theta}(x) = \int p_{\theta}(z)p_{\theta}(x|z)dz$

✓

↑

Simple Gaussian prior

Kingma and Welling, “Auto-Encoding Variational Bayes”, ICLR 2014

Variational Autoencoders: Intractability

Data likelihood: $p_{\theta}(x) = \int p_{\theta}(z) p_{\theta}(x|z) dz$

✓ ✓

Decoder neural network

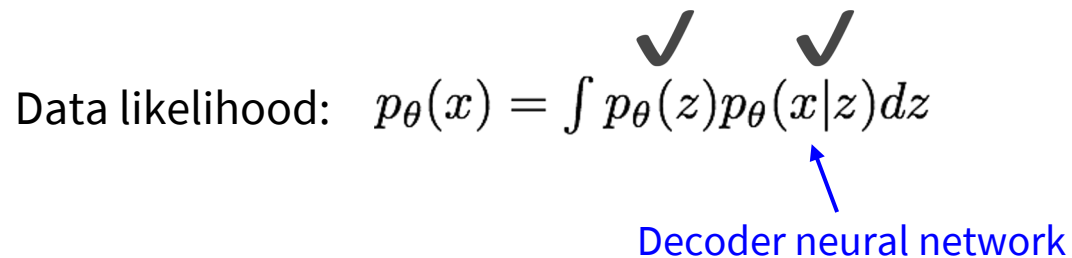
The diagram shows the equation for data likelihood in a Variational Autoencoder. The equation is $p_{\theta}(x) = \int p_{\theta}(z) p_{\theta}(x|z) dz$. Above the $p_{\theta}(z)$ and $p_{\theta}(x|z)$ terms, there are two checkmarks (✓). A blue arrow points from the text "Decoder neural network" below to the $p_{\theta}(x|z)$ term in the equation.

Kingma and Welling, "Auto-Encoding Variational Bayes", ICLR 2014

Variational Autoencoders: Intractability



Data likelihood: $p_{\theta}(x) = \int p_{\theta}(z)p_{\theta}(x|z)dz$

Intractable to compute $p(x|z)$ for every z !

Kingma and Welling, “Auto-Encoding Variational Bayes”, ICLR 2014

Variational Autoencoders: Intractability



Data likelihood: $p_{\theta}(x) = \int p_{\theta}(z)p_{\theta}(x|z)dz$

Intractable to compute $p(x|z)$ for every z !

$$\log p(x) \approx \log \frac{1}{k} \sum_{i=1}^k p(x|z^{(i)}), \text{ where } z^{(i)} \sim p(z)$$

Monte Carlo estimation is too high variance

Kingma and Welling, "Auto-Encoding Variational Bayes", ICLR 2014

Variational Autoencoders: Intractability



Data likelihood: $p_{\theta}(x) = \int p_{\theta}(z)p_{\theta}(x|z)dz$

Posterior density: $p_{\theta}(z|x) = p_{\theta}(x|z)p_{\theta}(z)/p_{\theta}(x)$



Intractable data likelihood

Kingma and Welling, “Auto-Encoding Variational Bayes”, ICLR 2014

Variational Autoencoders: Intractability

Data likelihood: $p_{\theta}(x) = \int p_{\theta}(z)p_{\theta}(x|z)dz$

Posterior density also intractable: $p_{\theta}(z|x) = p_{\theta}(x|z)p_{\theta}(z)/p_{\theta}(x)$

Solution: In addition to modeling $p_{\theta}(x|z)$, learn $q_{\phi}(z|x)$ that approximates the true posterior $p_{\theta}(z|x)$.

Will see that the approximate posterior allows us to derive a lower bound on the data likelihood that is tractable, which we can optimize.

Variational inference is to approximate the unknown posterior distribution from only the observed data x

Kingma and Welling, “Auto-Encoding Variational Bayes”, ICLR 2014

Variational Autoencoders

$$\log p_{\theta}(x^{(i)}) = \mathbf{E}_{z \sim q_{\phi}(z|x^{(i)})} [\log p_{\theta}(x^{(i)})] \quad (p_{\theta}(x^{(i)})) \text{ Does not depend on } z$$

Variational Autoencoders

$$\log p_{\theta}(x^{(i)}) = \mathbf{E}_{z \sim q_{\phi}(z|x^{(i)})} [\log p_{\theta}(x^{(i)})] \quad (p_{\theta}(x^{(i)}) \text{ Does not depend on } z)$$



Taking expectation wrt. z (using encoder network) will come in handy later

Variational Autoencoders

$$\begin{aligned}\log p_{\theta}(x^{(i)}) &= \mathbf{E}_{z \sim q_{\phi}(z|x^{(i)})} \left[\log p_{\theta}(x^{(i)}) \right] && (p_{\theta}(x^{(i)})) \text{ Does not depend on } z \\ &= \mathbf{E}_z \left[\log \frac{p_{\theta}(x^{(i)} | z)p_{\theta}(z)}{p_{\theta}(z | x^{(i)})} \right] && (\text{Bayes' Rule})\end{aligned}$$

Variational Autoencoders

$$\begin{aligned}\log p_{\theta}(x^{(i)}) &= \mathbf{E}_{z \sim q_{\phi}(z|x^{(i)})} \left[\log p_{\theta}(x^{(i)}) \right] && (p_{\theta}(x^{(i)})) \text{ Does not depend on } z \\ &= \mathbf{E}_z \left[\log \frac{p_{\theta}(x^{(i)} | z)p_{\theta}(z)}{p_{\theta}(z | x^{(i)})} \right] && (\text{Bayes' Rule}) \\ &= \mathbf{E}_z \left[\log \frac{p_{\theta}(x^{(i)} | z)p_{\theta}(z)}{p_{\theta}(z | x^{(i)})} \frac{q_{\phi}(z | x^{(i)})}{q_{\phi}(z | x^{(i)})} \right] && (\text{Multiply by constant})\end{aligned}$$

Variational Autoencoders

$$\begin{aligned}\log p_{\theta}(x^{(i)}) &= \mathbf{E}_{z \sim q_{\phi}(z|x^{(i)})} \left[\log p_{\theta}(x^{(i)}) \right] && (p_{\theta}(x^{(i)}) \text{ Does not depend on } z) \\ &= \mathbf{E}_z \left[\log \frac{p_{\theta}(x^{(i)} | z) p_{\theta}(z)}{p_{\theta}(z | x^{(i)})} \right] && (\text{Bayes' Rule}) \\ &= \mathbf{E}_z \left[\log \frac{p_{\theta}(x^{(i)} | z) p_{\theta}(z) q_{\phi}(z | x^{(i)})}{p_{\theta}(z | x^{(i)}) q_{\phi}(z | x^{(i)})} \right] && (\text{Multiply by constant}) \\ &= \mathbf{E}_z \left[\log p_{\theta}(x^{(i)} | z) \right] - \mathbf{E}_z \left[\log \frac{q_{\phi}(z | x^{(i)})}{p_{\theta}(z)} \right] + \mathbf{E}_z \left[\log \frac{q_{\phi}(z | x^{(i)})}{p_{\theta}(z | x^{(i)})} \right] && (\text{Logarithms})\end{aligned}$$

Variational Autoencoders

$$\begin{aligned}\log p_{\theta}(x^{(i)}) &= \mathbf{E}_{z \sim q_{\phi}(z|x^{(i)})} \left[\log p_{\theta}(x^{(i)}) \right] \quad (p_{\theta}(x^{(i)}) \text{ Does not depend on } z) \\ &= \mathbf{E}_z \left[\log \frac{p_{\theta}(x^{(i)} | z) p_{\theta}(z)}{p_{\theta}(z | x^{(i)})} \right] \quad (\text{Bayes' Rule}) \\ &= \mathbf{E}_z \left[\log \frac{p_{\theta}(x^{(i)} | z) p_{\theta}(z) q_{\phi}(z | x^{(i)})}{p_{\theta}(z | x^{(i)}) q_{\phi}(z | x^{(i)})} \right] \quad (\text{Multiply by constant}) \\ &= \mathbf{E}_z \left[\log p_{\theta}(x^{(i)} | z) \right] - \mathbf{E}_z \left[\log \frac{q_{\phi}(z | x^{(i)})}{p_{\theta}(z)} \right] + \mathbf{E}_z \left[\log \frac{q_{\phi}(z | x^{(i)})}{p_{\theta}(z | x^{(i)})} \right] \quad (\text{Logarithms}) \\ &= \mathbf{E}_z \left[\log p_{\theta}(x^{(i)} | z) \right] - D_{KL}(q_{\phi}(z | x^{(i)}) || p_{\theta}(z)) + D_{KL}(q_{\phi}(z | x^{(i)}) || p_{\theta}(z | x^{(i)}))\end{aligned}$$

←
The expectation wrt. z (using
encoder network) let us write
nice KL terms
→

Variational Autoencoders

$$\begin{aligned}\log p_{\theta}(x^{(i)}) &= \mathbf{E}_{z \sim q_{\phi}(z|x^{(i)})} \left[\log p_{\theta}(x^{(i)}) \right] \quad (p_{\theta}(x^{(i)}) \text{ Does not depend on } z) \\ &= \mathbf{E}_z \left[\log \frac{p_{\theta}(x^{(i)} | z) p_{\theta}(z)}{p_{\theta}(z | x^{(i)})} \right] \quad (\text{Bayes' Rule}) \\ &= \mathbf{E}_z \left[\log \frac{p_{\theta}(x^{(i)} | z) p_{\theta}(z) q_{\phi}(z | x^{(i)})}{p_{\theta}(z | x^{(i)}) q_{\phi}(z | x^{(i)})} \right] \quad (\text{Multiply by constant}) \\ &= \mathbf{E}_z \left[\log p_{\theta}(x^{(i)} | z) \right] - \mathbf{E}_z \left[\log \frac{q_{\phi}(z | x^{(i)})}{p_{\theta}(z)} \right] + \mathbf{E}_z \left[\log \frac{q_{\phi}(z | x^{(i)})}{p_{\theta}(z | x^{(i)})} \right] \quad (\text{Logarithms}) \\ &= \mathbf{E}_z \left[\log p_{\theta}(x^{(i)} | z) \right] - D_{KL}(q_{\phi}(z | x^{(i)}) || p_{\theta}(z)) + D_{KL}(q_{\phi}(z | x^{(i)}) || p_{\theta}(z | x^{(i)}))\end{aligned}$$

↑
Decoder network gives $p_{\theta}(x|z)$, can compute estimate of this term through sampling (need some trick to differentiate through sampling).

↑
This KL term (between Gaussians for encoder and z prior) has nice closed-form solution!

↑
 $p_{\theta}(z|x)$ intractable (saw earlier), can't compute this KL term :(
But we know KL divergence always ≥ 0 .

Variational Autoencoders

$$\log p_{\theta}(x^{(i)}) = \mathbf{E}_{z \sim q_{\phi}(z|x^{(i)})} \left[\log p_{\theta}(x^{(i)}) \right] \quad (p_{\theta}(x^{(i)}) \text{ Does not depend on } z)$$

We want to maximize the data likelihood

$$= \mathbf{E}_z \left[\log \frac{p_{\theta}(x^{(i)} | z) p_{\theta}(z)}{p_{\theta}(z | x^{(i)})} \right] \quad (\text{Bayes' Rule})$$

$$= \mathbf{E}_z \left[\log \frac{p_{\theta}(x^{(i)} | z) p_{\theta}(z) q_{\phi}(z | x^{(i)})}{p_{\theta}(z | x^{(i)}) q_{\phi}(z | x^{(i)})} \right] \quad (\text{Multiply by constant})$$

$$= \mathbf{E}_z \left[\log p_{\theta}(x^{(i)} | z) \right] - \mathbf{E}_z \left[\log \frac{q_{\phi}(z | x^{(i)})}{p_{\theta}(z)} \right] + \mathbf{E}_z \left[\log \frac{q_{\phi}(z | x^{(i)})}{p_{\theta}(z | x^{(i)})} \right] \quad (\text{Logarithms})$$

$$= \mathbf{E}_z \left[\log p_{\theta}(x^{(i)} | z) \right] - D_{KL}(q_{\phi}(z | x^{(i)}) || p_{\theta}(z)) + D_{KL}(q_{\phi}(z | x^{(i)}) || p_{\theta}(z | x^{(i)}))$$

Decoder network gives $p_{\theta}(x|z)$, can compute estimate of this term through sampling.

This KL term (between Gaussians for encoder and z prior) has nice closed-form solution!

$p_{\theta}(z|x)$ intractable (saw earlier), can't compute this KL term :(
But we know KL divergence always ≥ 0 .

Variational Autoencoders

We want to maximize the data likelihood

$$\begin{aligned}\log p_{\theta}(x^{(i)}) &= \mathbf{E}_{z \sim q_{\phi}(z|x^{(i)})} \left[\log p_{\theta}(x^{(i)}) \right] \quad (p_{\theta}(x^{(i)}) \text{ Does not depend on } z) \\ &= \mathbf{E}_z \left[\log \frac{p_{\theta}(x^{(i)} | z) p_{\theta}(z)}{p_{\theta}(z | x^{(i)})} \right] \quad (\text{Bayes' Rule}) \\ &= \mathbf{E}_z \left[\log \frac{p_{\theta}(x^{(i)} | z) p_{\theta}(z) q_{\phi}(z | x^{(i)})}{p_{\theta}(z | x^{(i)}) q_{\phi}(z | x^{(i)})} \right] \quad (\text{Multiply by constant}) \\ &= \mathbf{E}_z \left[\log p_{\theta}(x^{(i)} | z) \right] - \mathbf{E}_z \left[\log \frac{q_{\phi}(z | x^{(i)})}{p_{\theta}(z)} \right] + \mathbf{E}_z \left[\log \frac{q_{\phi}(z | x^{(i)})}{p_{\theta}(z | x^{(i)})} \right] \quad (\text{Logarithms}) \\ &= \underbrace{\mathbf{E}_z \left[\log p_{\theta}(x^{(i)} | z) \right] - D_{KL}(q_{\phi}(z | x^{(i)}) || p_{\theta}(z))}_{\mathcal{L}(x^{(i)}, \theta, \phi)} + \underbrace{D_{KL}(q_{\phi}(z | x^{(i)}) || p_{\theta}(z | x^{(i)}))}_{\geq 0}\end{aligned}$$

Tractable lower bound which we can take gradient of and optimize! ($p_{\theta}(x|z)$ differentiable, KL term differentiable)

Variational Autoencoders

$$\log p_{\theta}(x^{(i)}) = \mathbf{E}_{z \sim q_{\phi}(z|x^{(i)})} \left[\log p_{\theta}(x^{(i)}) \right] \quad (p_{\theta}(x^{(i)}) \text{ Does not depend on } z)$$

$$= \mathbf{E}_z \left[\log \frac{p_{\theta}(x^{(i)} | z) p_{\theta}(z)}{p_{\theta}(z | x^{(i)})} \right] \quad (\text{Bayes' Rule})$$

Decoder:
reconstruct
the input data

$$= \mathbf{E}_z \left[\log \frac{p_{\theta}(x^{(i)} | z) p_{\theta}(z) q_{\phi}(z | x^{(i)})}{p_{\theta}(z | x^{(i)}) q_{\phi}(z | x^{(i)})} \right] \quad (\text{Multiply by constant})$$

Encoder:
make approximate
posterior distribution
close to prior

$$= \mathbf{E}_z \left[\log p_{\theta}(x^{(i)} | z) \right] - \mathbf{E}_z \left[\log \frac{q_{\phi}(z | x^{(i)})}{p_{\theta}(z)} \right] + \mathbf{E}_z \left[\log \frac{q_{\phi}(z | x^{(i)})}{p_{\theta}(z | x^{(i)})} \right] \quad (\text{Logarithms})$$

$$= \underbrace{\mathbf{E}_z \left[\log p_{\theta}(x^{(i)} | z) \right] - D_{KL}(q_{\phi}(z | x^{(i)}) || p_{\theta}(z))}_{\mathcal{L}(x^{(i)}, \theta, \phi)} + \underbrace{D_{KL}(q_{\phi}(z | x^{(i)}) || p_{\theta}(z | x^{(i)}))}_{\geq 0}$$

Tractable lower bound which we can take
gradient of and optimize! ($p_{\theta}(x|z)$ differentiable,
KL term differentiable)

Variational Autoencoders

Putting it all together: maximizing the likelihood lower bound

$$\underbrace{\mathbf{E}_z \left[\log p_\theta(x^{(i)} | z) \right] - D_{KL}(q_\phi(z | x^{(i)}) || p_\theta(z))}_{\mathcal{L}(x^{(i)}, \theta, \phi)}$$

Variational Autoencoders

Putting it all together: maximizing the likelihood lower bound

$$\underbrace{\mathbf{E}_z \left[\log p_\theta(x^{(i)} | z) \right]}_{\mathcal{L}(x^{(i)}, \theta, \phi)} - D_{KL}(q_\phi(z | x^{(i)}) || p_\theta(z))$$

Let's look at computing the KL divergence between the estimated posterior and the prior given some data

Input Data

\mathcal{X}

Variational Autoencoders

Putting it all together: maximizing the likelihood lower bound

$$\underbrace{\mathbf{E}_z \left[\log p_\theta(x^{(i)} | z) \right]}_{\mathcal{L}(x^{(i)}, \theta, \phi)} - D_{KL}(q_\phi(z | x^{(i)}) || p_\theta(z))$$

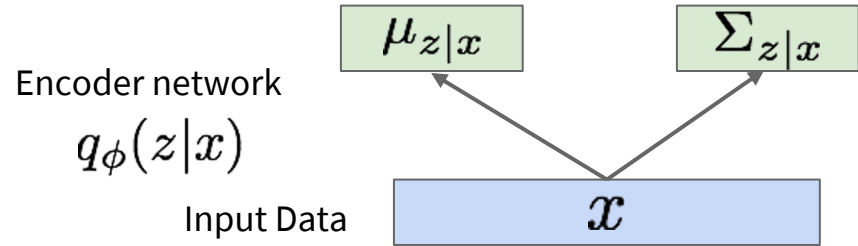

Variational Autoencoders

Putting it all together: maximizing the likelihood lower bound

$$\underbrace{\mathbb{E}_z \left[\log p_\theta(x^{(i)} | z) \right]}_{\mathcal{L}(x^{(i)}, \theta, \phi)} - \boxed{D_{KL}(q_\phi(z | x^{(i)}) || p_\theta(z))}$$

Make approximate posterior distribution close to prior

$$D_{KL}(\mathcal{N}(\mu_{z|x}, \Sigma_{z|x}) || \mathcal{N}(0, I))$$

Have analytical solution

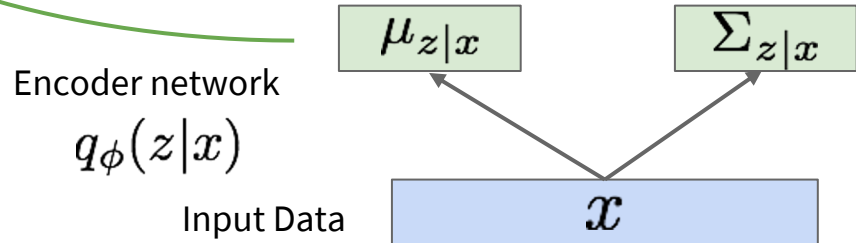

Variational Autoencoders

Putting it all together: maximizing the likelihood lower bound

$$\underbrace{\mathbb{E}_z \left[\log p_\theta(x^{(i)} | z) \right] - D_{KL}(q_\phi(z | x^{(i)}) || p_\theta(z))}_{\mathcal{L}(x^{(i)}, \theta, \phi)}$$

Make approximate posterior distribution close to prior

Encoder network

$$q_\phi(z|x)$$

Input Data

Not part of the computation graph!

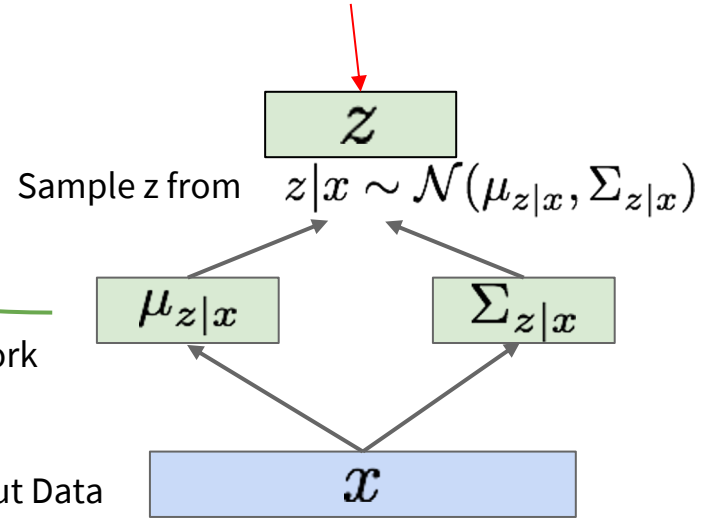

Variational Autoencoders

Putting it all together: maximizing the likelihood lower bound

$$\underbrace{\mathbb{E}_z \left[\log p_\theta(x^{(i)} | z) \right] - D_{KL}(q_\phi(z | x^{(i)}) || p_\theta(z))}_{\mathcal{L}(x^{(i)}, \theta, \phi)}$$

Reparameterization trick to make sampling differentiable:

Sample $\epsilon \sim \mathcal{N}(0, I)$

$$z = \mu_{z|x} + \epsilon \sigma_{z|x}$$

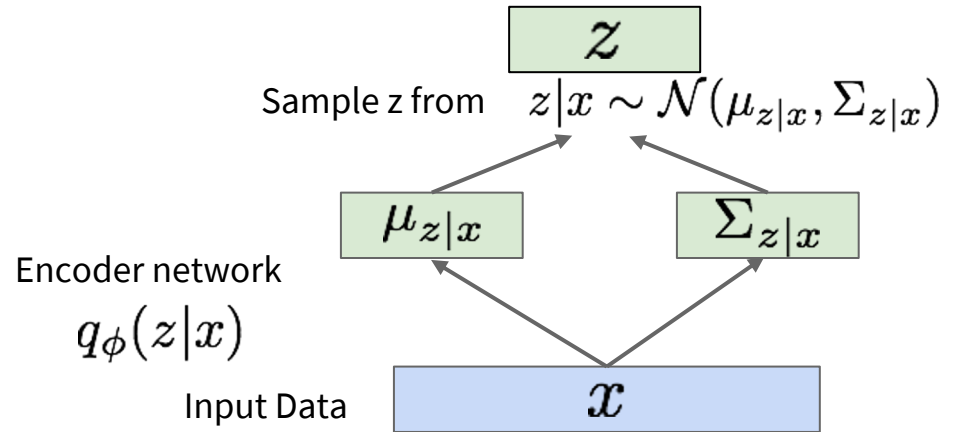

Variational Autoencoders

Putting it all together: maximizing the likelihood lower bound

$$\underbrace{\mathbb{E}_z \left[\log p_\theta(x^{(i)} | z) \right] - D_{KL}(q_\phi(z | x^{(i)}) || p_\theta(z))}_{\mathcal{L}(x^{(i)}, \theta, \phi)}$$

Reparameterization trick to make sampling differentiable:

Sample $\epsilon \sim \mathcal{N}(0, I)$ Input to the graph

$$z = \mu_{z|x} + \epsilon \sigma_{z|x}$$

Part of computation graph

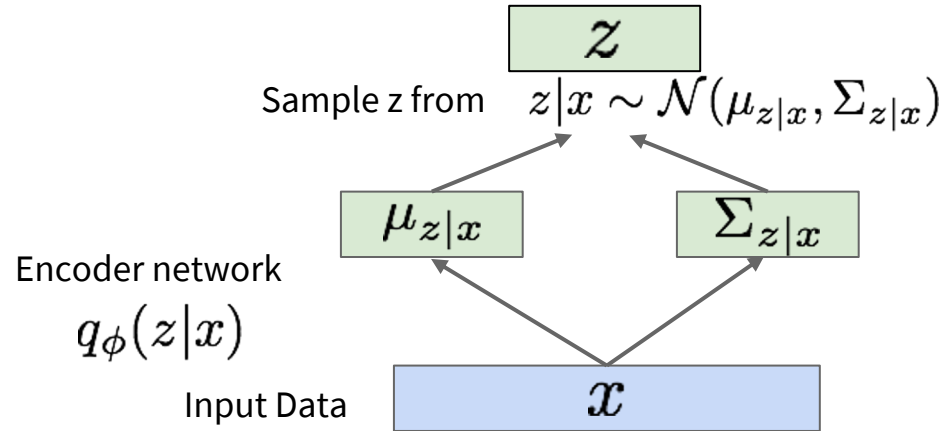

Variational Autoencoders

Putting it all together: maximizing the likelihood lower bound

$$\underbrace{\mathbb{E}_z \left[\log p_\theta(x^{(i)} | z) \right] - D_{KL}(q_\phi(z | x^{(i)}) || p_\theta(z))}_{\mathcal{L}(x^{(i)}, \theta, \phi)}$$

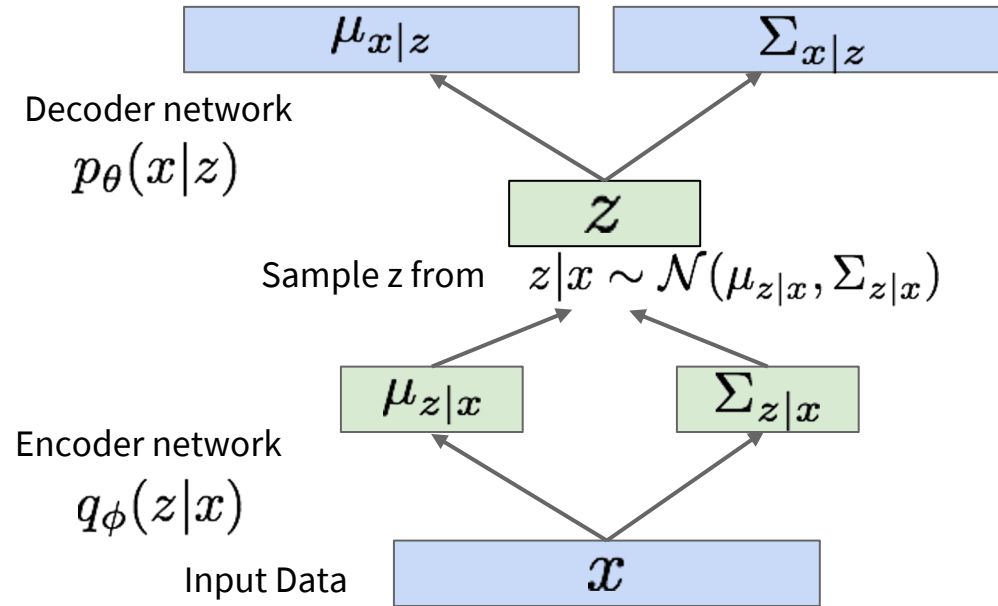

Variational Autoencoders

Putting it all together: maximizing the likelihood lower bound

$$\underbrace{\mathbb{E}_z \left[\log p_\theta(x^{(i)} | z) \right]}_{\mathcal{L}(x^{(i)}, \theta, \phi)} - D_{KL}(q_\phi(z | x^{(i)}) || p_\theta(z))$$

Maximize likelihood of original input being reconstructed

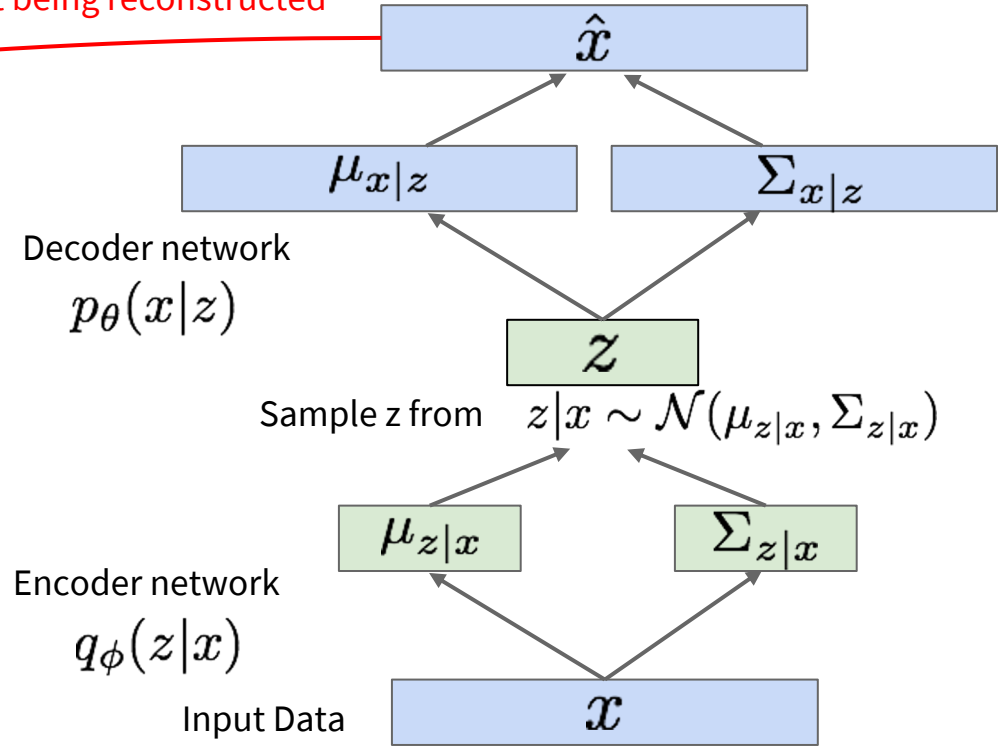

Variational Autoencoders

Putting it all together: maximizing the likelihood lower bound

$$\underbrace{\mathbf{E}_z \left[\log p_\theta(x^{(i)} | z) \right] - D_{KL}(q_\phi(z | x^{(i)}) || p_\theta(z))}_{\mathcal{L}(x^{(i)}, \theta, \phi)}$$

For every minibatch of input data: compute this forward pass, and then backprop!

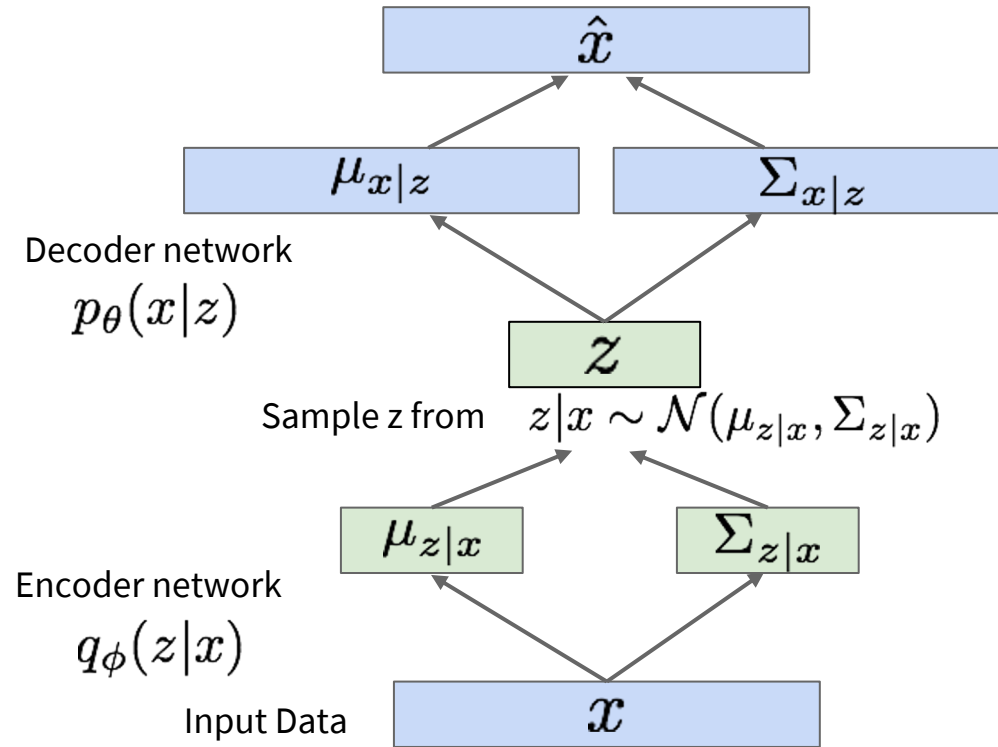

Variational Autoencoders: Generating Data!

Our assumption about data generation process

Sample from true conditional

$$p_{\theta^*}(x | z^{(i)})$$

Sample from true prior

$$z^{(i)} \sim p_{\theta^*}(z)$$

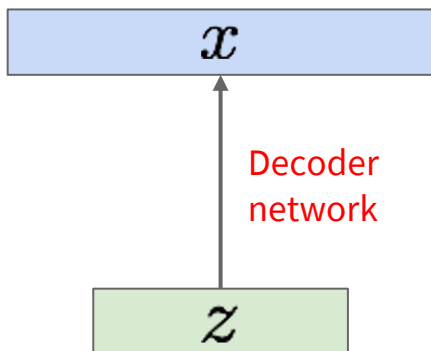

Kingma and Welling, "Auto-Encoding Variational Bayes", ICLR 2014

Variational Autoencoders: Generating Data!

Our assumption about data generation process

Sample from true conditional

$$p_{\theta^*}(x | z^{(i)})$$

Sample from true prior

$$z^{(i)} \sim p_{\theta^*}(z)$$

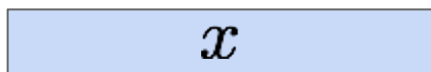

Decoder network

Now given a trained VAE:
use decoder network & sample z from prior!

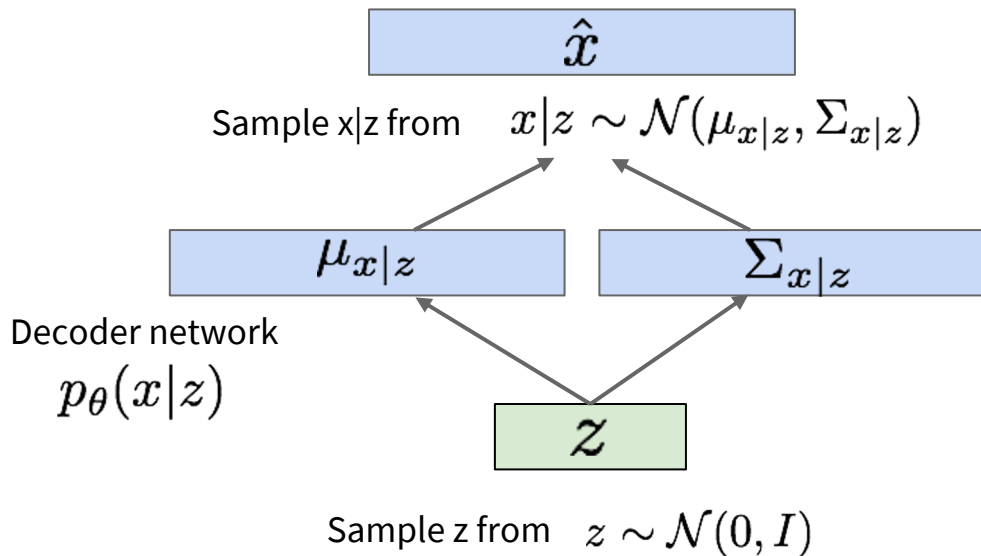

Kingma and Welling, "Auto-Encoding Variational Bayes", ICLR 2014

Variational Autoencoders: Generating Data!

Use decoder network. Now sample z from prior!

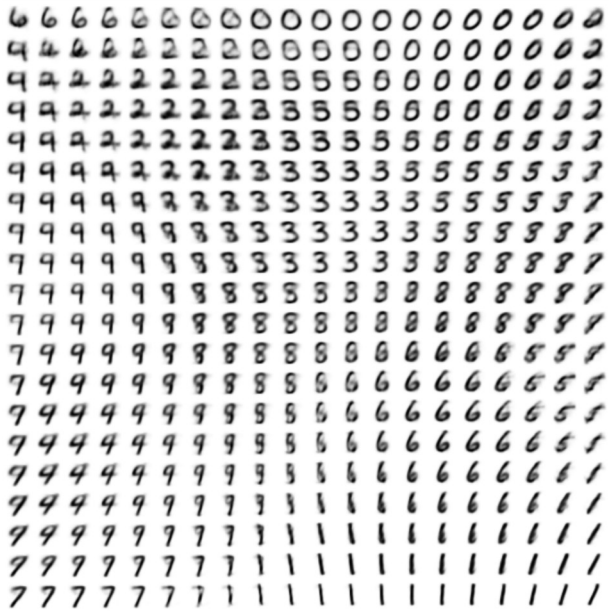
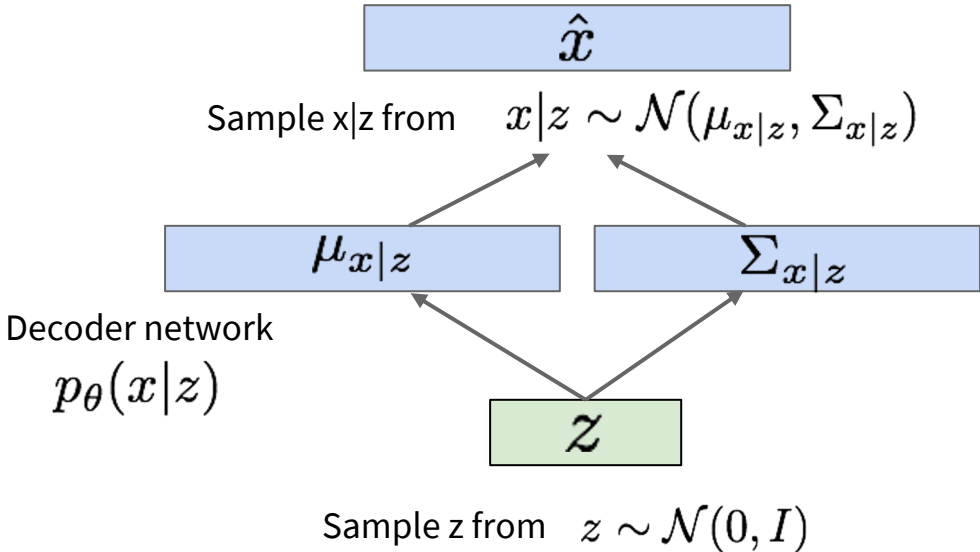

Kingma and Welling, "Auto-Encoding Variational Bayes", ICLR 2014

Variational Autoencoders: Generating Data!

Use decoder network. Now sample z from prior!

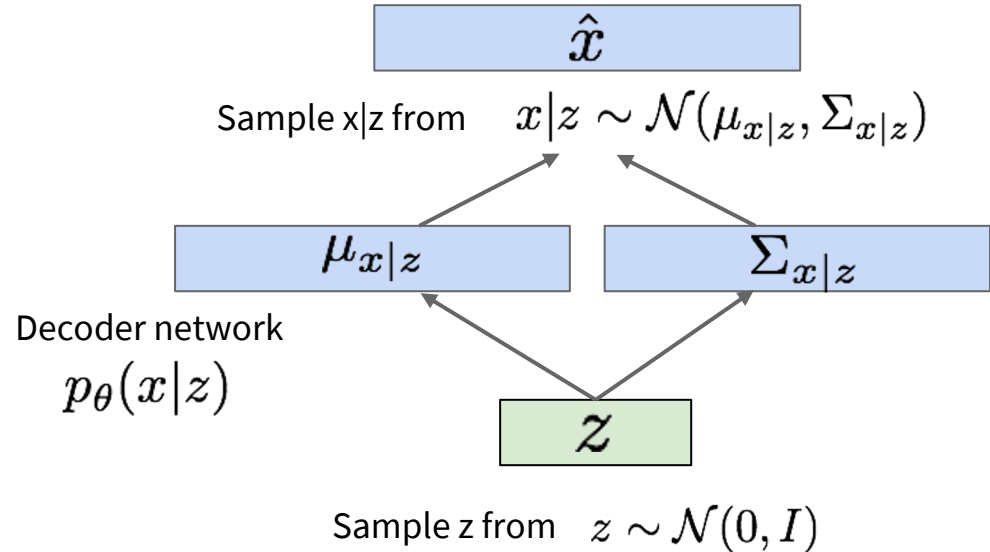

Data manifold for 2-d z

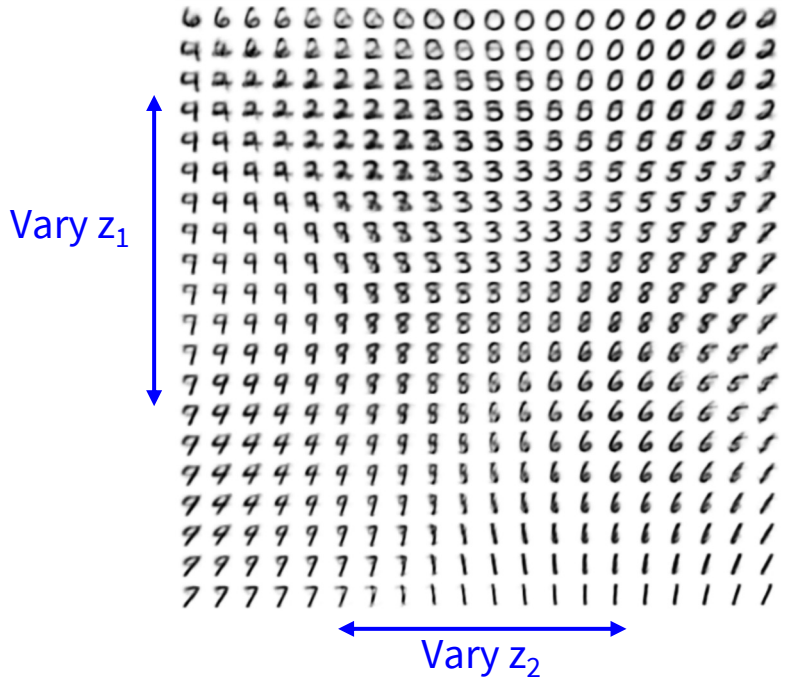

Kingma and Welling, "Auto-Encoding Variational Bayes", ICLR 2014

Variational Autoencoders: Generating Data!

Diagonal prior on z
=> independent
latent variables

Different dimensions
of z encode
interpretable factors
of variation

Degree of smile

Vary z_1



Vary z_2

Head pose

Kingma and Welling, "Auto-Encoding Variational Bayes", ICLR 2014

Variational Autoencoders: Generating Data!

Diagonal prior on z
=> independent
latent variables

Different dimensions
of z encode
interpretable factors
of variation

Also good feature representation that
can be computed using $q_\phi(z|x)$!

Degree of smile

Vary z_1



Vary z_2

Head pose

Kingma and Welling, "Auto-Encoding Variational Bayes", ICLR 2014

Variational Autoencoders: Generating Data!



32x32 CIFAR-10



Labeled Faces in the Wild

Figures copyright (L) Dirk Kingma et al. 2016; (R) Anders Larsen et al. 2017. Reproduced with permission.

Variational Autoencoders

Probabilistic spin to traditional autoencoders => allows generating data
Defines an intractable density => derive and optimize a (variational) lower bound

Pros:

- Principled approach to generative models
- Interpretable latent space.
- Allows inference of $q(z|x)$, can be useful feature representation for other tasks

Cons:

- Maximizes lower bound of likelihood: okay, but not as good evaluation as PixelRNN/PixelCNN
- Samples blurrier and lower quality compared to state-of-the-art (GANs)

Active areas of research:

- More flexible approximations, e.g. richer approximate posterior instead of diagonal Gaussian, e.g., Gaussian Mixture Models (GMMs), Categorical Distributions.
- Learning disentangled representations.

Taxonomy of Generative Models

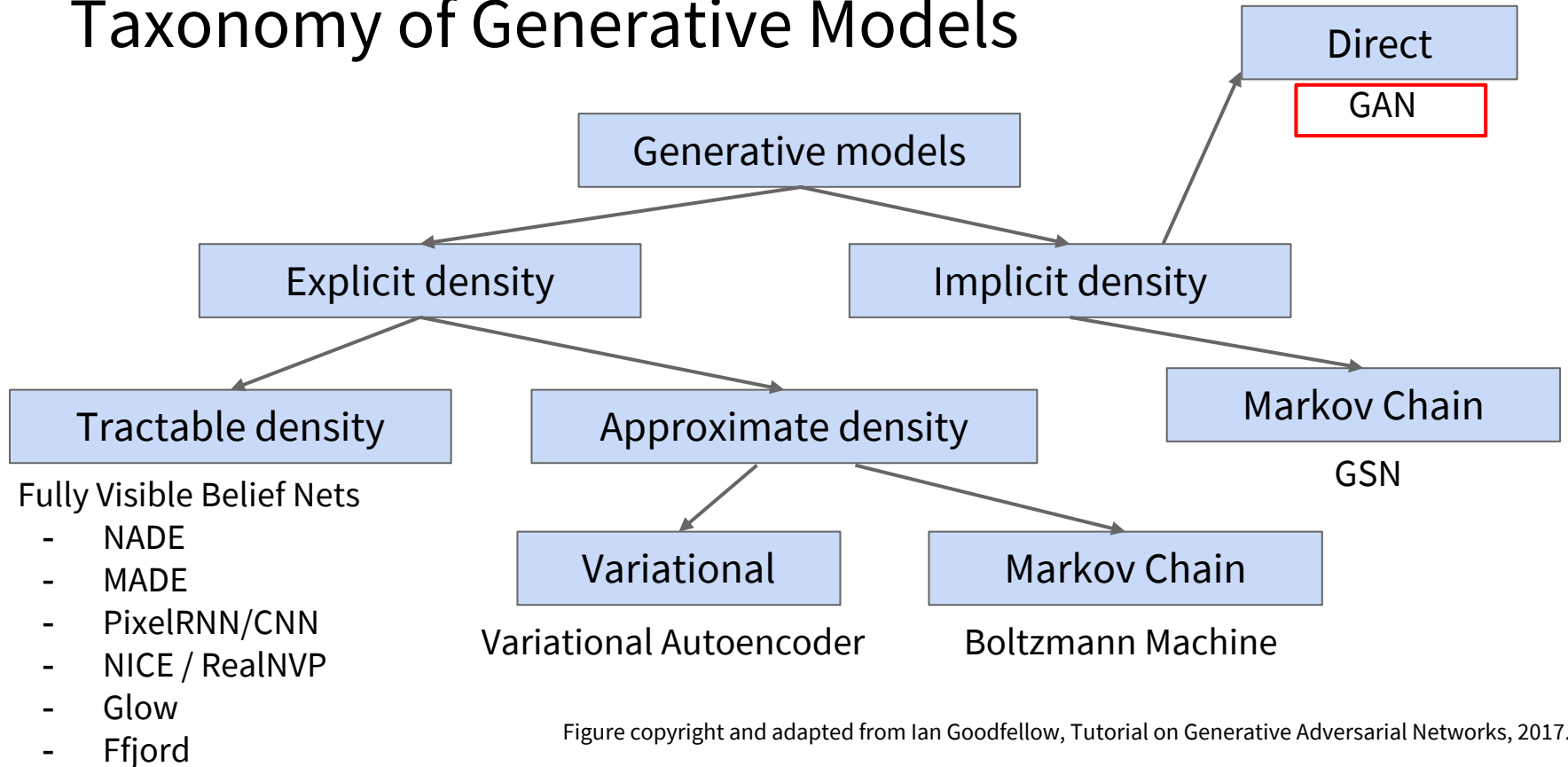

Figure copyright and adapted from Ian Goodfellow, Tutorial on Generative Adversarial Networks, 2017.

Generative Adversarial Networks (GANs)

So far...

PixelRNN/CNNs define tractable density function, optimize likelihood of training data:

$$p_{\theta}(x) = \prod_{i=1}^n p_{\theta}(x_i | x_1, \dots, x_{i-1})$$

VAEs define intractable density function with latent z :

$$p_{\theta}(x) = \int p_{\theta}(z) p_{\theta}(x|z) dz$$

Cannot optimize directly, derive and optimize lower bound on likelihood instead

So far...

PixelRNN/CNNs define tractable density function, optimize likelihood of training data:

$$p_{\theta}(x) = \prod_{i=1}^n p_{\theta}(x_i | x_1, \dots, x_{i-1})$$

VAEs define intractable density function with latent z :

$$p_{\theta}(x) = \int p_{\theta}(z) p_{\theta}(x|z) dz$$

Cannot optimize directly, derive and optimize lower bound on likelihood instead

What if we give up on explicitly modeling density, and just want ability to sample?

So far...

PixelRNN/CNNs define tractable density function, optimize likelihood of training data:

$$p_{\theta}(x) = \prod_{i=1}^n p_{\theta}(x_i | x_1, \dots, x_{i-1})$$

VAEs define intractable density function with latent z :

$$p_{\theta}(x) = \int p_{\theta}(z) p_{\theta}(x|z) dz$$

Cannot optimize directly, derive and optimize lower bound on likelihood instead

What if we give up on explicitly modeling density, and just want ability to sample?

GANs: not modeling any explicit density function!

Generative Adversarial Networks

Ian Goodfellow et al., “Generative Adversarial Nets”, NIPS 2014

Problem: Want to sample from complex, high-dimensional training distribution. No direct way to do this!

Solution: Sample from a simple distribution we can easily sample from, e.g. random noise. Learn transformation to training distribution.

Generative Adversarial Networks

Ian Goodfellow et al., “Generative Adversarial Nets”, NIPS 2014

Problem: Want to sample from complex, high-dimensional training distribution. No direct way to do this!

Solution: Sample from a simple distribution we can easily sample from, e.g. random noise. Learn transformation to training distribution.

Output: Sample from training distribution

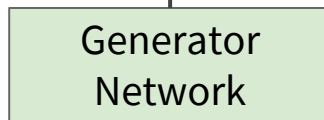
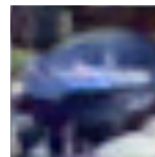

Input: Random noise

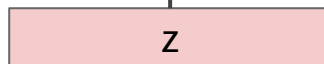

Generative Adversarial Networks

Ian Goodfellow et al., “Generative Adversarial Nets”, NIPS 2014

Problem: Want to sample from complex, high-dimensional training distribution. No direct way to do this!

Solution: Sample from a simple distribution we can easily sample from, e.g. random noise. Learn transformation to training distribution.

But we don't know which sample z maps to which training image -> can't learn by reconstructing training images

Output: Sample from training distribution

Input: Random noise

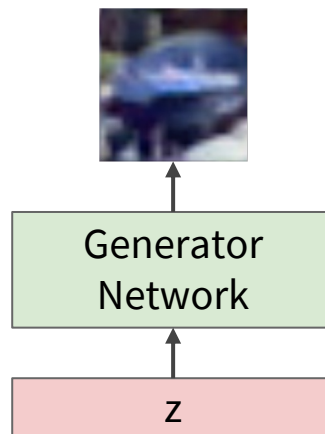

Generative Adversarial Networks

Ian Goodfellow et al., “Generative Adversarial Nets”, NIPS 2014

Problem: Want to sample from complex, high-dimensional training distribution. No direct way to do this!

Solution: Sample from a simple distribution we can easily sample from, e.g. random noise. Learn transformation to training distribution.

But we don't know which sample z maps to which training image -> can't learn by reconstructing training images

Output: Sample from training distribution



Objective: generated images should look “real”

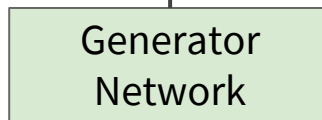

Input: Random noise

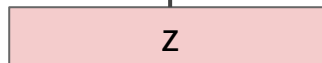

Generative Adversarial Networks

Ian Goodfellow et al., “Generative Adversarial Nets”, NIPS 2014

Problem: Want to sample from complex, high-dimensional training distribution. No direct way to do this!

Solution: Sample from a simple distribution we can easily sample from, e.g. random noise. Learn transformation to training distribution.

But we don't know which sample z maps to which training image -> can't learn by reconstructing training images

Solution: Use a discriminator network to tell whether the generate image is within data distribution (“real”) or not

Output: Sample from training distribution

Input: Random noise

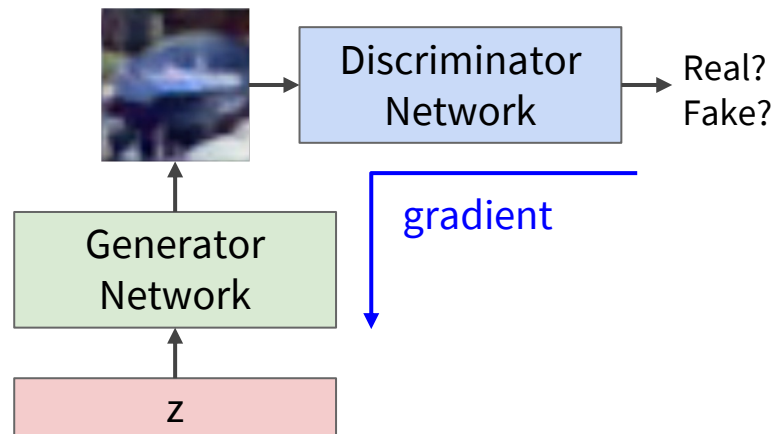

Training GANs: Two-player game

Ian Goodfellow et al., “Generative Adversarial Nets”, NIPS 2014

Discriminator network: try to distinguish between real and fake images

Generator network: try to fool the discriminator by generating real-looking images

Training GANs: Two-player game

Ian Goodfellow et al., "Generative Adversarial Nets", NIPS 2014

Discriminator network: try to distinguish between real and fake images

Generator network: try to fool the discriminator by generating real-looking images

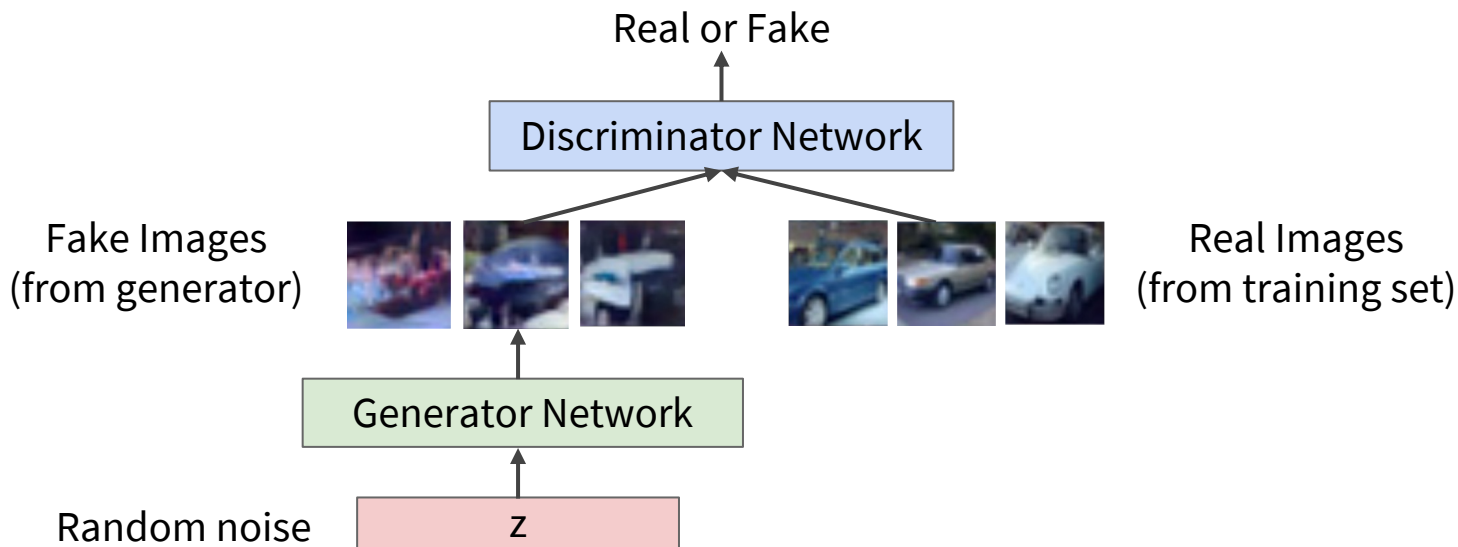

Fake and real images copyright Emily Denton et al. 2015. Reproduced with permission.

Training GANs: Two-player game

Ian Goodfellow et al., "Generative Adversarial Nets", NIPS 2014

Discriminator network: try to distinguish between real and fake images

Generator network: try to fool the discriminator by generating real-looking images

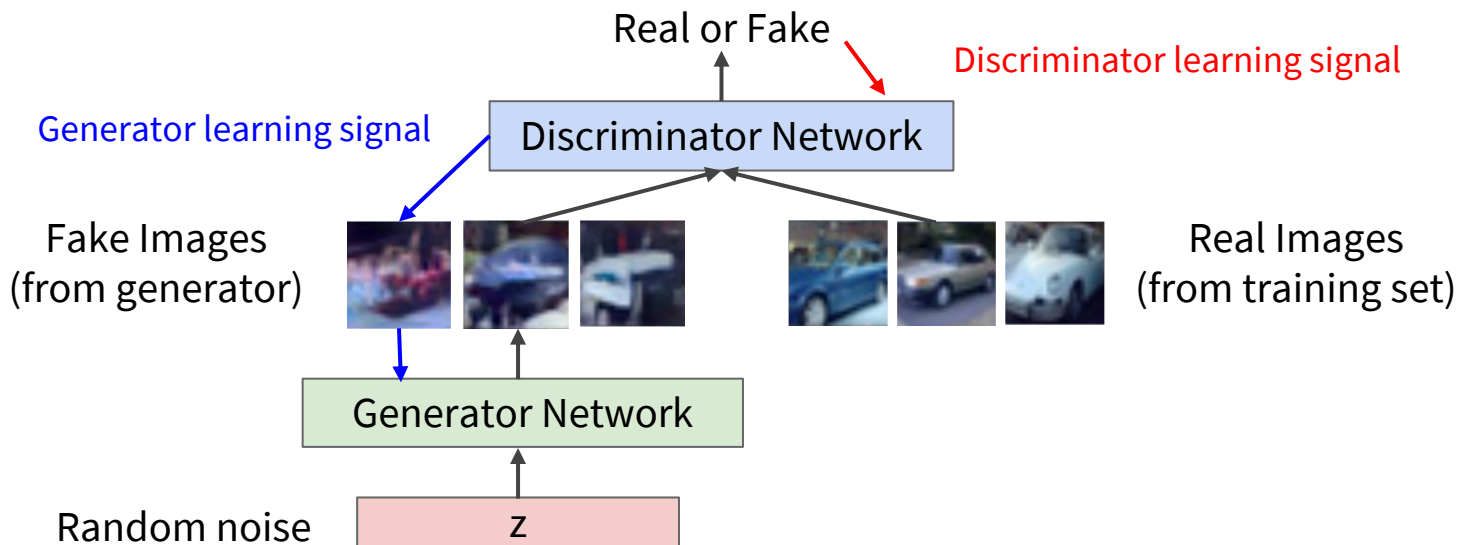

Fake and real images copyright Emily Denton et al. 2015. Reproduced with permission.

Training GANs: Two-player game

Ian Goodfellow et al., “Generative Adversarial Nets”, NIPS 2014

Discriminator network: try to distinguish between real and fake images

Generator network: try to fool the discriminator by generating real-looking images

Train jointly in **minimax game**

Minimax objective function:

$$\min_{\theta_g} \max_{\theta_d} \left[\mathbb{E}_{x \sim p_{data}} \log D_{\theta_d}(x) + \mathbb{E}_{z \sim p(z)} \log(1 - D_{\theta_d}(G_{\theta_g}(z))) \right]$$

Generator objective

Discriminator objective

Training GANs: Two-player game

Ian Goodfellow et al., "Generative Adversarial Nets", NIPS 2014

Discriminator network: try to distinguish between real and fake images

Generator network: try to fool the discriminator by generating real-looking images

Train jointly in minimax game

Minimax objective function:

$$\min_{\theta_g} \max_{\theta_d} \left[\mathbb{E}_{x \sim p_{data}} \log \underbrace{D_{\theta_d}(x)}_{\substack{\text{Discriminator output} \\ \text{for real data } x}} + \mathbb{E}_{z \sim p(z)} \log(1 - \underbrace{D_{\theta_d}(G_{\theta_g}(z))}_{\substack{\text{Discriminator output for} \\ \text{generated fake data } G(z)}}) \right]$$

Discriminator outputs likelihood in (0,1) of real image

Training GANs: Two-player game

Ian Goodfellow et al., "Generative Adversarial Nets", NIPS 2014

Discriminator network: try to distinguish between real and fake images

Generator network: try to fool the discriminator by generating real-looking images

Train jointly in minimax game

Minimax objective function:

$$\min_{\theta_g} \max_{\theta_d} \left[\mathbb{E}_{x \sim p_{data}} \log \underbrace{D_{\theta_d}(x)}_{\substack{\text{Discriminator output} \\ \text{for real data } x}} + \mathbb{E}_{z \sim p(z)} \log(1 - \underbrace{D_{\theta_d}(G_{\theta_g}(z))}_{\substack{\text{Discriminator output for} \\ \text{generated fake data } G(z)}}) \right]$$

Discriminator outputs likelihood in (0,1) of real image

Training GANs: Two-player game

Ian Goodfellow et al., "Generative Adversarial Nets", NIPS 2014

Discriminator network: try to distinguish between real and fake images

Generator network: try to fool the discriminator by generating real-looking images

Train jointly in minimax game

Minimax objective function:

$$\min_{\theta_g} \max_{\theta_d} \left[\mathbb{E}_{x \sim p_{data}} \log \underbrace{D_{\theta_d}(x)}_{\substack{\text{Discriminator output} \\ \text{for real data } x}} + \mathbb{E}_{z \sim p(z)} \log(1 - \underbrace{D_{\theta_d}(G_{\theta_g}(z))}_{\substack{\text{Discriminator output for} \\ \text{generated fake data } G(z)}}) \right]$$

Discriminator outputs likelihood in (0,1) of real image

Training GANs: Two-player game

Ian Goodfellow et al., “Generative Adversarial Nets”, NIPS 2014

Discriminator network: try to distinguish between real and fake images

Generator network: try to fool the discriminator by generating real-looking images

Train jointly in minimax game

Minimax objective function:

Discriminator outputs likelihood in (0,1) of real image

$$\min_{\theta_g} \max_{\theta_d} \left[\mathbb{E}_{x \sim p_{data}} \log \underbrace{D_{\theta_d}(x)}_{\substack{\text{Discriminator output} \\ \text{for real data } x}} + \mathbb{E}_{z \sim p(z)} \log(1 - \underbrace{D_{\theta_d}(G_{\theta_g}(z))}_{\substack{\text{Discriminator output for} \\ \text{generated fake data } G(z)}}) \right]$$

- Discriminator (θ_d) wants to maximize objective such that $D(x)$ is close to 1 (real) and $D(G(z))$ is close to 0 (fake)
- Generator (θ_g) wants to minimize objective such that $D(G(z))$ is close to 1 (discriminator is fooled into thinking generated $G(z)$ is real)

Training GANs: Two-player game

Ian Goodfellow et al., “Generative Adversarial Nets”, NIPS 2014

Minimax objective function:

$$\min_{\theta_g} \max_{\theta_d} \left[\mathbb{E}_{x \sim p_{data}} \log D_{\theta_d}(x) + \mathbb{E}_{z \sim p(z)} \log(1 - D_{\theta_d}(G_{\theta_g}(z))) \right]$$

Alternate between:

1. Gradient ascent on discriminator

$$\max_{\theta_d} \left[\mathbb{E}_{x \sim p_{data}} \log D_{\theta_d}(x) + \mathbb{E}_{z \sim p(z)} \log(1 - D_{\theta_d}(G_{\theta_g}(z))) \right]$$

2. Gradient descent on generator

$$\min_{\theta_g} \mathbb{E}_{z \sim p(z)} \log(1 - D_{\theta_d}(G_{\theta_g}(z)))$$

Training GANs: Two-player game

Ian Goodfellow et al., “Generative Adversarial Nets”, NIPS 2014

Minimax objective function:

$$\min_{\theta_g} \max_{\theta_d} \left[\mathbb{E}_{x \sim p_{data}} \log D_{\theta_d}(x) + \mathbb{E}_{z \sim p(z)} \log(1 - D_{\theta_d}(G_{\theta_g}(z))) \right]$$

Alternate between:

1. Gradient ascent on discriminator

$$\max_{\theta_d} \left[\mathbb{E}_{x \sim p_{data}} \log D_{\theta_d}(x) + \mathbb{E}_{z \sim p(z)} \log(1 - D_{\theta_d}(G_{\theta_g}(z))) \right]$$

2. Gradient descent on generator

$$\min_{\theta_g} \mathbb{E}_{z \sim p(z)} \log(1 - D_{\theta_d}(G_{\theta_g}(z)))$$

In practice, optimizing this generator objective does not work well!

When sample is likely fake, want to learn from it to improve generator (move to the right on X axis).

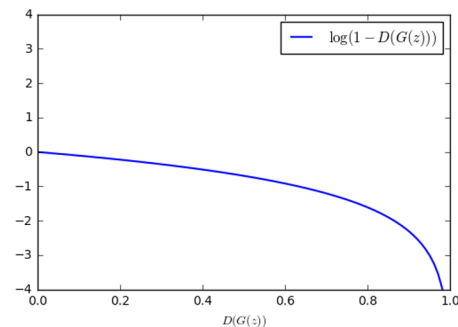

Training GANs: Two-player game

Minimax objective function:

$$\min_{\theta_g} \max_{\theta_d} \left[\mathbb{E}_{x \sim p_{data}} \log D_{\theta_d}(x) + \mathbb{E}_{z \sim p(z)} \log(1 - D_{\theta_d}(G_{\theta_g}(z))) \right]$$

Alternate between:

1. Gradient ascent on discriminator

$$\max_{\theta_d} \left[\mathbb{E}_{x \sim p_{data}} \log D_{\theta_d}(x) + \mathbb{E}_{z \sim p(z)} \log(1 - D_{\theta_d}(G_{\theta_g}(z))) \right]$$

2. Gradient descent on generator

$$\min_{\theta_g} \mathbb{E}_{z \sim p(z)} \log(1 - D_{\theta_d}(G_{\theta_g}(z)))$$

In practice, optimizing this generator objective does not work well!

When sample is likely fake, want to learn from it to improve generator (move to the right on X axis).

But gradient in this region is relatively flat!

Gradient signal dominated by region where sample is already good

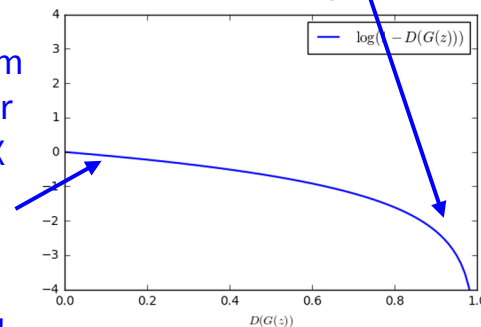

Training GANs: Two-player game

Ian Goodfellow et al., “Generative Adversarial Nets”, NIPS 2014

Minimax objective function:

$$\min_{\theta_g} \max_{\theta_d} \left[\mathbb{E}_{x \sim p_{data}} \log D_{\theta_d}(x) + \mathbb{E}_{z \sim p(z)} \log(1 - D_{\theta_d}(G_{\theta_g}(z))) \right]$$

Alternate between:

1. Gradient ascent on discriminator

$$\max_{\theta_d} \left[\mathbb{E}_{x \sim p_{data}} \log D_{\theta_d}(x) + \mathbb{E}_{z \sim p(z)} \log(1 - D_{\theta_d}(G_{\theta_g}(z))) \right]$$

2. Instead: Gradient **ascent** on generator, **different objective**

$$\max_{\theta_g} \mathbb{E}_{z \sim p(z)} \log(D_{\theta_d}(G_{\theta_g}(z)))$$

Instead of minimizing likelihood of discriminator being correct, now maximize likelihood of discriminator being wrong.

Same objective of fooling discriminator, but now higher gradient signal for bad samples => works much better! Standard in practice.

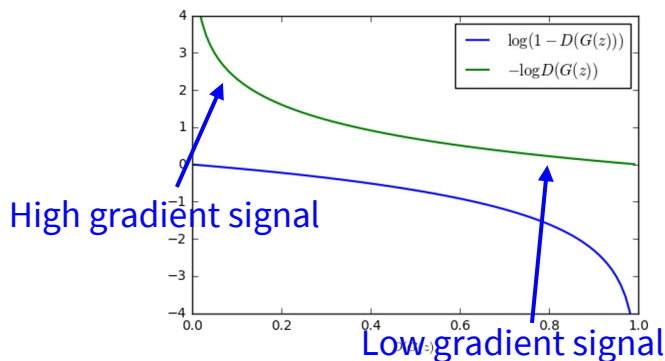

Training GANs: Two-player game

Ian Goodfellow et al., “Generative Adversarial Nets”, NIPS 2014

Putting it together: GAN training algorithm

for number of training iterations **do**

for k steps **do**

- Sample minibatch of m noise samples $\{\mathbf{z}^{(1)}, \dots, \mathbf{z}^{(m)}\}$ from noise prior $p_g(\mathbf{z})$.
- Sample minibatch of m examples $\{\mathbf{x}^{(1)}, \dots, \mathbf{x}^{(m)}\}$ from data generating distribution $p_{\text{data}}(\mathbf{x})$.
- Update the discriminator by ascending its stochastic gradient:

$$\nabla_{\theta_d} \frac{1}{m} \sum_{i=1}^m \left[\log D_{\theta_d}(x^{(i)}) + \log(1 - D_{\theta_d}(G_{\theta_g}(z^{(i)}))) \right]$$

end for

- Sample minibatch of m noise samples $\{\mathbf{z}^{(1)}, \dots, \mathbf{z}^{(m)}\}$ from noise prior $p_g(\mathbf{z})$.
- Update the generator by ascending its stochastic gradient (improved objective):

$$\nabla_{\theta_g} \frac{1}{m} \sum_{i=1}^m \log(D_{\theta_d}(G_{\theta_g}(z^{(i)})))$$

end for

Training GANs: Two-player game

Ian Goodfellow et al., "Generative Adversarial Nets", NIPS 2014

Putting it together: GAN training algorithm

for number of training iterations **do**

for k steps **do**

- Sample minibatch of m noise samples $\{\mathbf{z}^{(1)}, \dots, \mathbf{z}^{(m)}\}$ from noise prior $p_g(\mathbf{z})$.
- Sample minibatch of m examples $\{\mathbf{x}^{(1)}, \dots, \mathbf{x}^{(m)}\}$ from data generating distribution $p_{\text{data}}(\mathbf{x})$.
- Update the discriminator by ascending its stochastic gradient:

$$\nabla_{\theta_d} \frac{1}{m} \sum_{i=1}^m \left[\log D_{\theta_d}(x^{(i)}) + \log(1 - D_{\theta_d}(G_{\theta_g}(z^{(i)}))) \right]$$

end for

- Sample minibatch of m noise samples $\{\mathbf{z}^{(1)}, \dots, \mathbf{z}^{(m)}\}$ from noise prior $p_g(\mathbf{z})$.
- Update the generator by ascending its stochastic gradient (improved objective):

$$\nabla_{\theta_g} \frac{1}{m} \sum_{i=1}^m \log(D_{\theta_d}(G_{\theta_g}(z^{(i)})))$$

end for

Some find $k=1$ more stable, others use $k > 1$, no best rule.

Followup work (e.g. Wasserstein GAN, BEGAN) alleviates this problem, better stability!

Arjovsky et al. "Wasserstein gan." arXiv preprint arXiv:1701.07875 (2017)

Berthelot, et al. "Began: Boundary equilibrium generative adversarial networks." arXiv preprint arXiv:1703.10717 (2017)

Training GANs: Two-player game

Ian Goodfellow et al., "Generative Adversarial Nets", NIPS 2014

Generator network: try to fool the discriminator by generating real-looking images

Discriminator network: try to distinguish between real and fake images

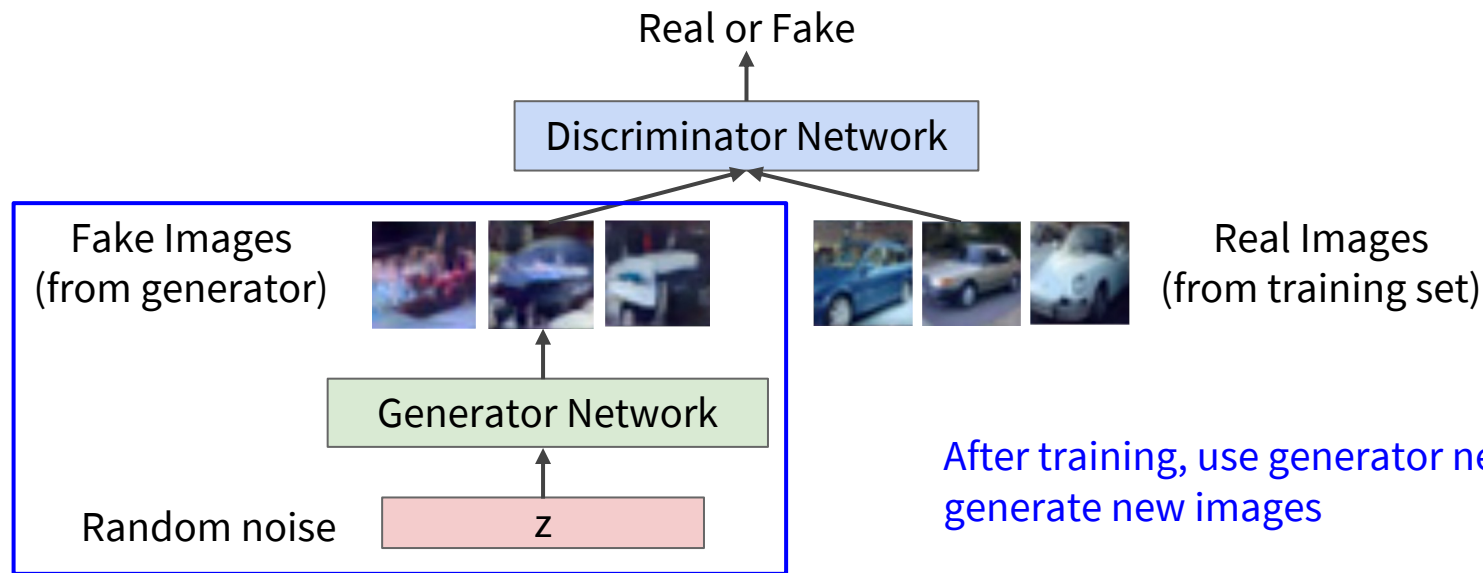

Fake and real images copyright Emily Denton et al. 2015. Reproduced with permission.

Generative Adversarial Nets

Generated samples

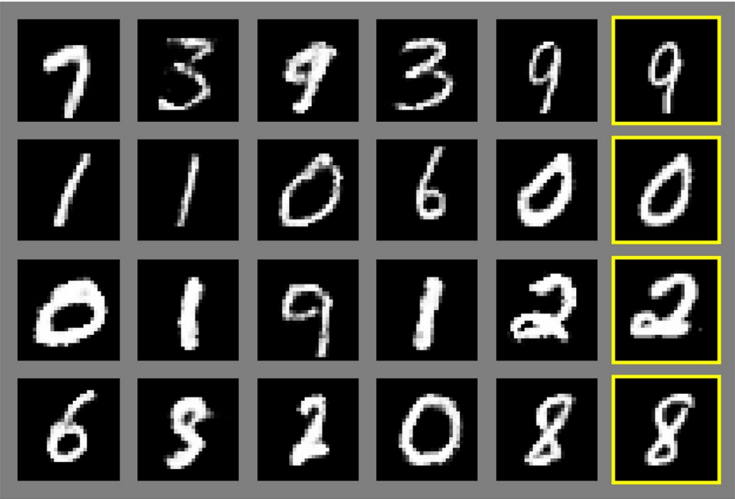

Nearest neighbor from training set

Figures copyright Ian Goodfellow et al., 2014. Reproduced with permission.

Generative Adversarial Nets

Generated samples (CIFAR-10)



Nearest neighbor from training set

Figures copyright Ian Goodfellow et al., 2014. Reproduced with permission.

Generative Adversarial Nets: Convolutional Architectures

Generator is an upsampling network with fractionally-strided convolutions
Discriminator is a convolutional network

Architecture guidelines for stable Deep Convolutional GANs

- Replace any pooling layers with strided convolutions (discriminator) and fractional-strided convolutions (generator).
- Use batchnorm in both the generator and the discriminator.
- Remove fully connected hidden layers for deeper architectures.
- Use ReLU activation in generator for all layers except for the output, which uses Tanh.
- Use LeakyReLU activation in the discriminator for all layers.

Radford et al, “Unsupervised Representation Learning with Deep Convolutional Generative Adversarial Networks”, ICLR 2016

Generative Adversarial Nets: Convolutional Architectures

Samples from the model look much better!



Radford et al,
ICLR 2016

Generative Adversarial Nets: Convolutional Architectures

Interpolating
between
random
points in latent
space



Radford et al,
ICLR 2016

Generative Adversarial Nets: Interpretable Vector Math

Radford et al, ICLR 2016

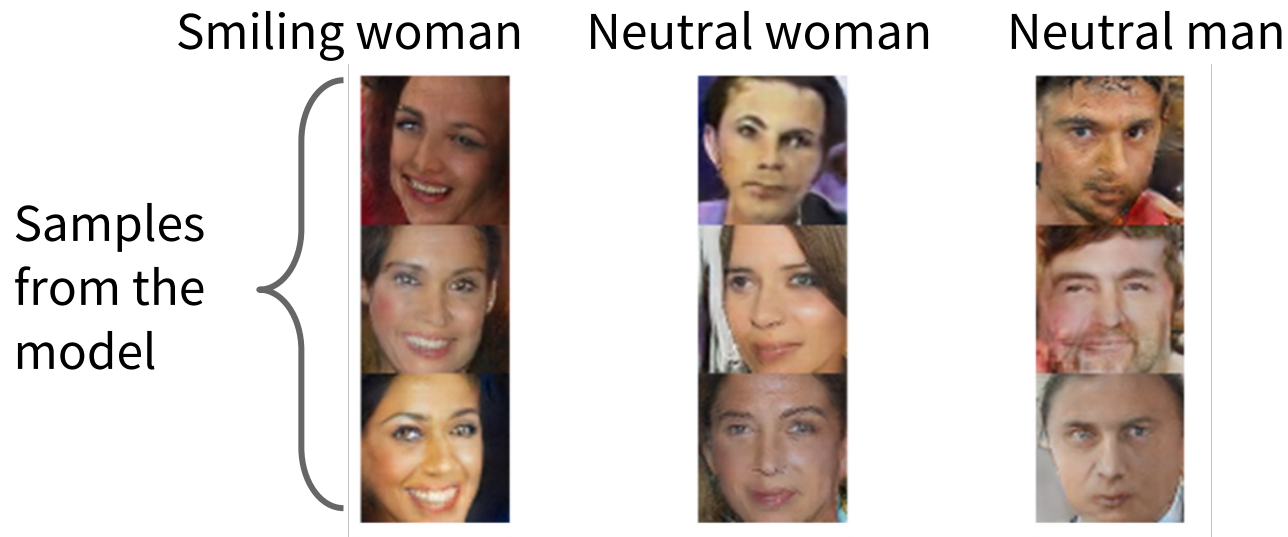

Generative Adversarial Nets: Interpretable Vector Math

Radford et al, ICLR 2016

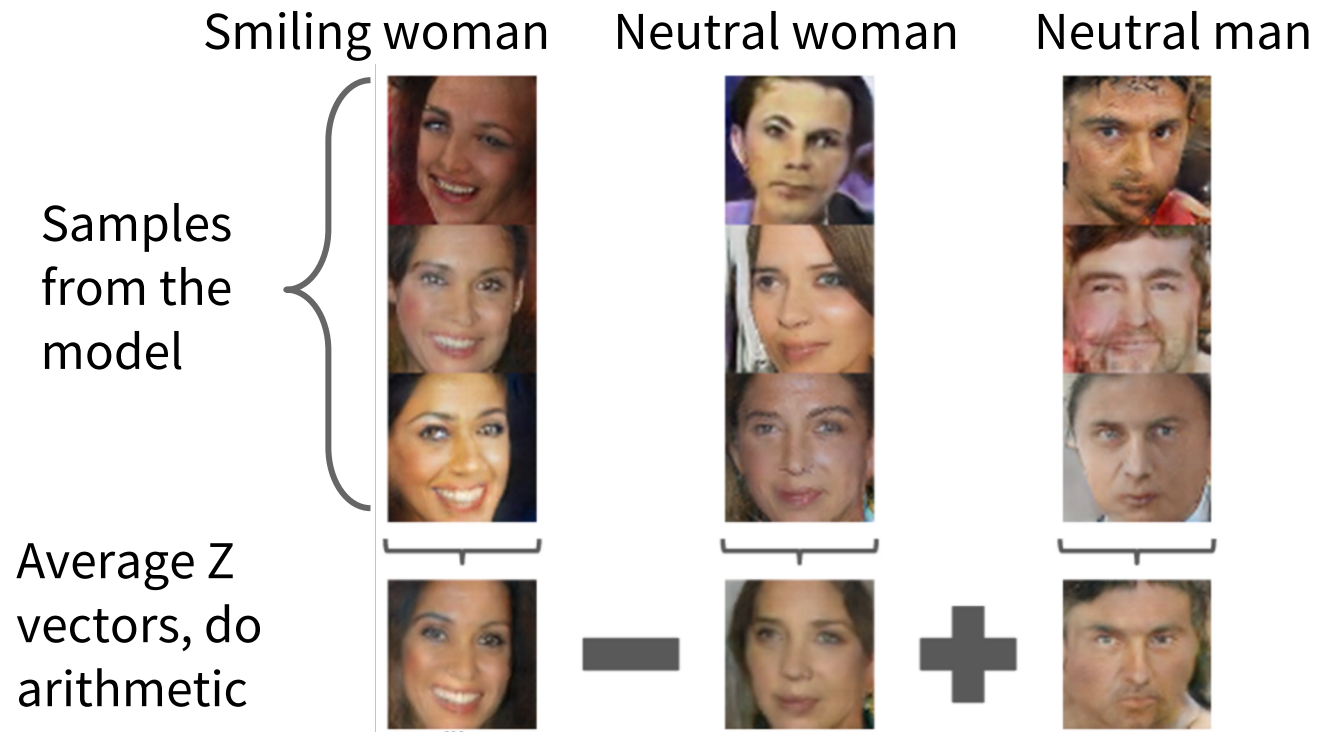

Generative Adversarial Nets: Interpretable Vector Math

Radford et al, ICLR 2016

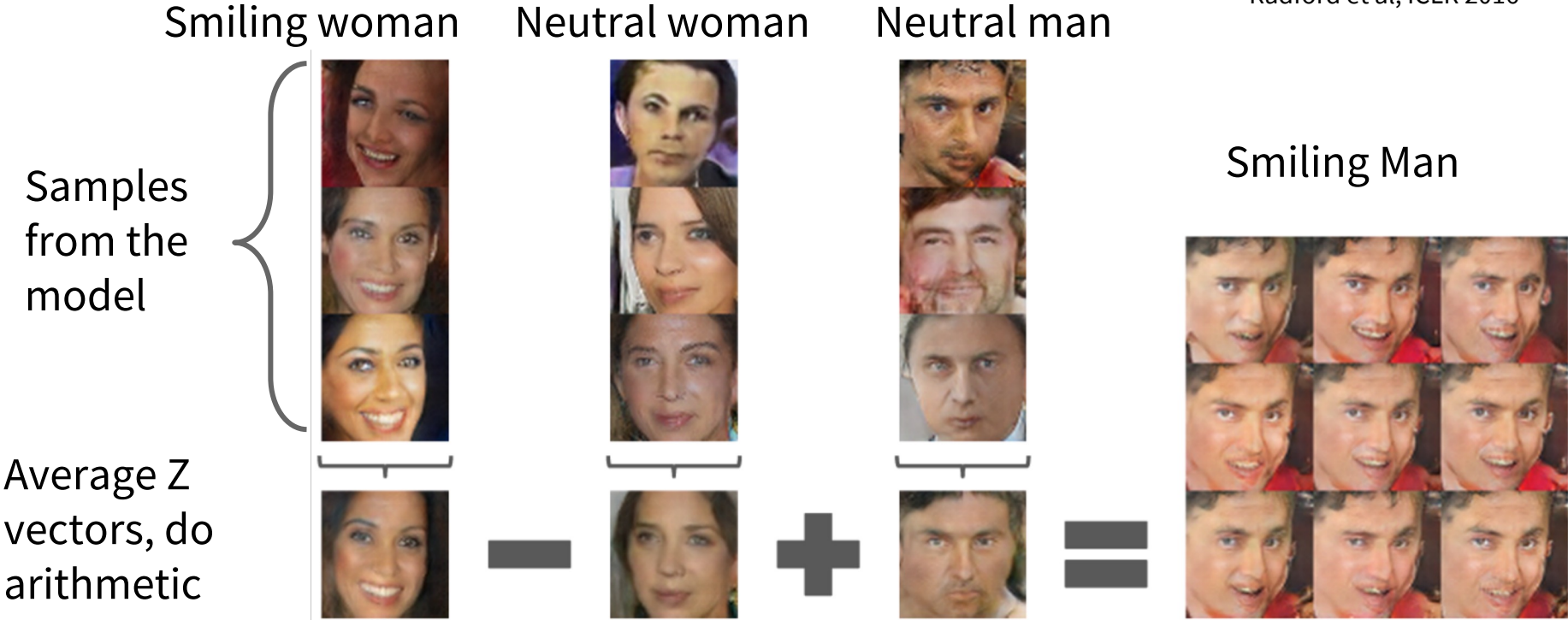

Generative Adversarial Nets: Interpretable Vector Math

Glasses man



No glasses man



-

No glasses woman



+

=

Woman with glasses



Radford et al,
ICLR 2016

2017: Explosion of GANs

“The GAN Zoo”

- GAN - Generative Adversarial Networks
- 3D-GAN - Learning a Probabilistic Latent Space of Object Shapes via 3D Generative-Adversarial Modeling
- acGAN - Face Aging With Conditional Generative Adversarial Networks
- AC-GAN - Conditional Image Synthesis With Auxiliary Classifier GANs
- AdaGAN - AdaGAN: Boosting Generative Models
- AEGAN - Learning Inverse Mapping by Autoencoder based Generative Adversarial Nets
- AffGAN - Amortised MAP Inference for Image Super-resolution
- AL-CGAN - Learning to Generate Images of Outdoor Scenes from Attributes and Semantic Layouts
- ALI - Adversarially Learned Inference
- AM-GAN - Generative Adversarial Nets with Labeled Data by Activation Maximization
- AnoGAN - Unsupervised Anomaly Detection with Generative Adversarial Networks to Guide Marker Discovery
- ArtGAN - ArtGAN: Artwork Synthesis with Conditional Categorical GANs
- b-GAN - b-GAN: Unified Framework of Generative Adversarial Networks
- Bayesian GAN - Deep and Hierarchical Implicit Models
- BEGAN - BEGAN: Boundary Equilibrium Generative Adversarial Networks
- BiGAN - Adversarial Feature Learning
- BS-GAN - Boundary-Seeking Generative Adversarial Networks
- CGAN - Conditional Generative Adversarial Nets
- CaloGAN - CaloGAN: Simulating 3D High Energy Particle Showers in Multi-Layer Electromagnetic Calorimeters with Generative Adversarial Networks
- CCGAN - Semi-Supervised Learning with Context-Conditional Generative Adversarial Networks
- CatGAN - Unsupervised and Semi-supervised Learning with Categorical Generative Adversarial Networks
- CoGAN - Coupled Generative Adversarial Networks

See also: <https://github.com/soumith/ganhacks> for tips and tricks for trainings GANs

- Context-RNN-GAN - Contextual RNN-GANs for Abstract Reasoning Diagram Generation
- C-RNN-GAN - C-RNN-GAN: Continuous recurrent neural networks with adversarial training
- CS-GAN - Improving Neural Machine Translation with Conditional Sequence Generative Adversarial Nets
- CVAE-GAN - CVAE-GAN: Fine-Grained Image Generation through Asymmetric Training
- CycleGAN - Unpaired Image-to-Image Translation using Cycle-Consistent Adversarial Networks
- DTN - Unsupervised Cross-Domain Image Generation
- DCGAN - Unsupervised Representation Learning with Deep Convolutional Generative Adversarial Networks
- DiscoGAN - Learning to Discover Cross-Domain Relations with Generative Adversarial Networks
- DR-GAN - Disentangled Representation Learning GAN for Pose-Invariant Face Recognition
- DualGAN - DualGAN: Unsupervised Dual Learning for Image-to-Image Translation
- EBGAN - Energy-based Generative Adversarial Network
- f-GAN - f-GAN: Training Generative Neural Samplers using Variational Divergence Minimization
- FF-GAN - Towards Large-Pose Face Frontalization in the Wild
- GAWWN - Learning What and Where to Draw
- GeneGAN - GeneGAN: Learning Object Transfiguration and Attribute Subspace from Unpaired Data
- Geometric GAN - Geometric GAN
- GoGAN - Gang of GANs: Generative Adversarial Networks with Maximum Margin Ranking
- GP-GAN - GP-GAN: Towards Realistic High-Resolution Image Blending
- IAN - Neural Photo Editing with Introspective Adversarial Networks
- iGAN - Generative Visual Manipulation on the Natural Image Manifold
- IcGAN - Invertible Conditional GANs for image editing
- ID-CGAN - Image De-raining Using a Conditional Generative Adversarial Network
- Improved GAN - Improved Techniques for Training GANs
- InfoGAN - InfoGAN: Interpretable Representation Learning by Information Maximizing Generative Adversarial Nets
- LAGAN - Learning Particle Physics by Example: Location-Aware Generative Adversarial Networks for Physics Synthesis
- LAPGAN - Deep Generative Image Models using a Laplacian Pyramid of Adversarial Networks

<https://github.com/hindupuravinash/the-gan-zoo>

2017: Explosion of GANs

Better training and generation



LSGAN, Zhu 2017.



Wasserstein GAN, Arjovsky 2017.
Improved Wasserstein GAN,
Gulrajani 2017.



Progressive GAN, Karras 2018.

2017: Explosion of GANs

Source->Target domain transfer



CycleGAN. Zhu et al. 2017.

Text -> Image Synthesis

this small bird has a pink breast and crown, and black primaries and secondaries.

this magnificent fellow is almost all black with a red crest, and white cheek patch.



Reed et al. 2017.

Many GAN applications



Pix2pix. Isola 2017. Many examples at <https://phillipi.github.io/pix2pix/>

2019: BigGAN



Brock et al., 2019

Summary: GANs

Don't work with an explicit density function

Take game-theoretic approach: learn to generate from training distribution through 2-player game

Pros:

- Beautiful samples!

Cons:

- Trickier / more unstable to train
- Can't solve inference queries such as $p(x)$, $p(z|x)$

Active areas of research:

- Better loss functions, more stable training (Wasserstein GAN, LSGAN, many others)
- Conditional GANs, GANs for all kinds of applications

Summary

Autoregressive models:
PixelRNN, PixelCNN

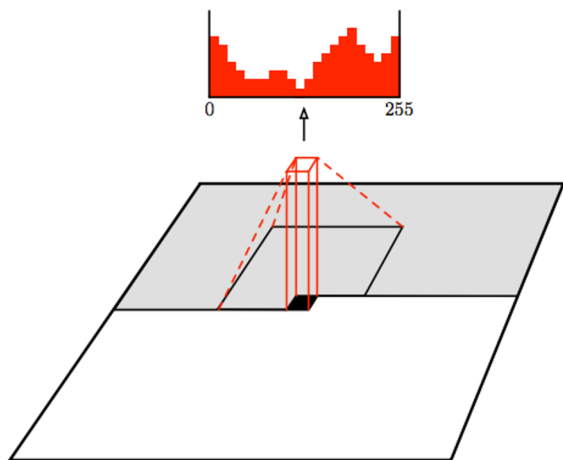

Van der Oord et al, "Conditional image generation with pixelCNN decoders", NIPS 2016

Variational Autoencoders

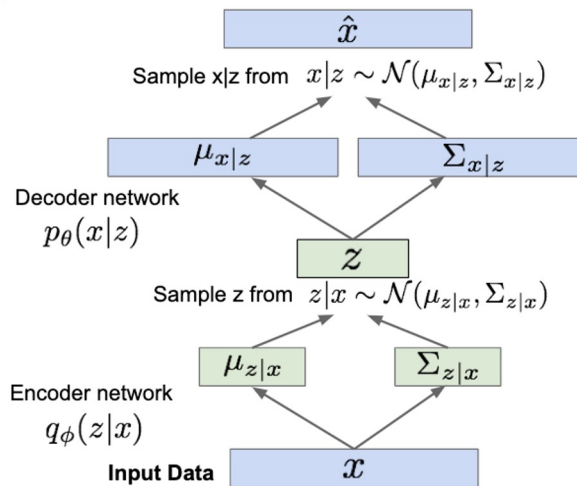

Kingma and Welling, "Auto-encoding variational bayes", ICLR 2013

Generative Adversarial Networks (GANs)

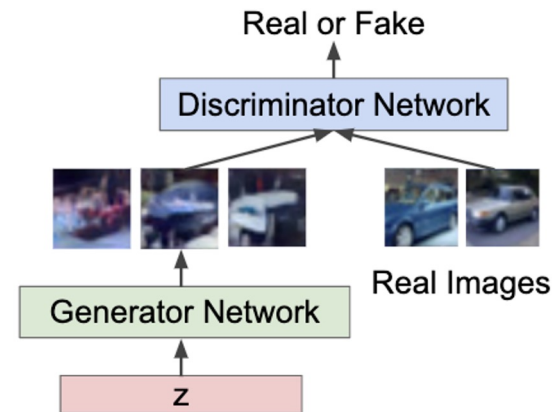

Goodfellow et al, "Generative Adversarial Nets", NIPS 2014

Taxonomy of Generative Models

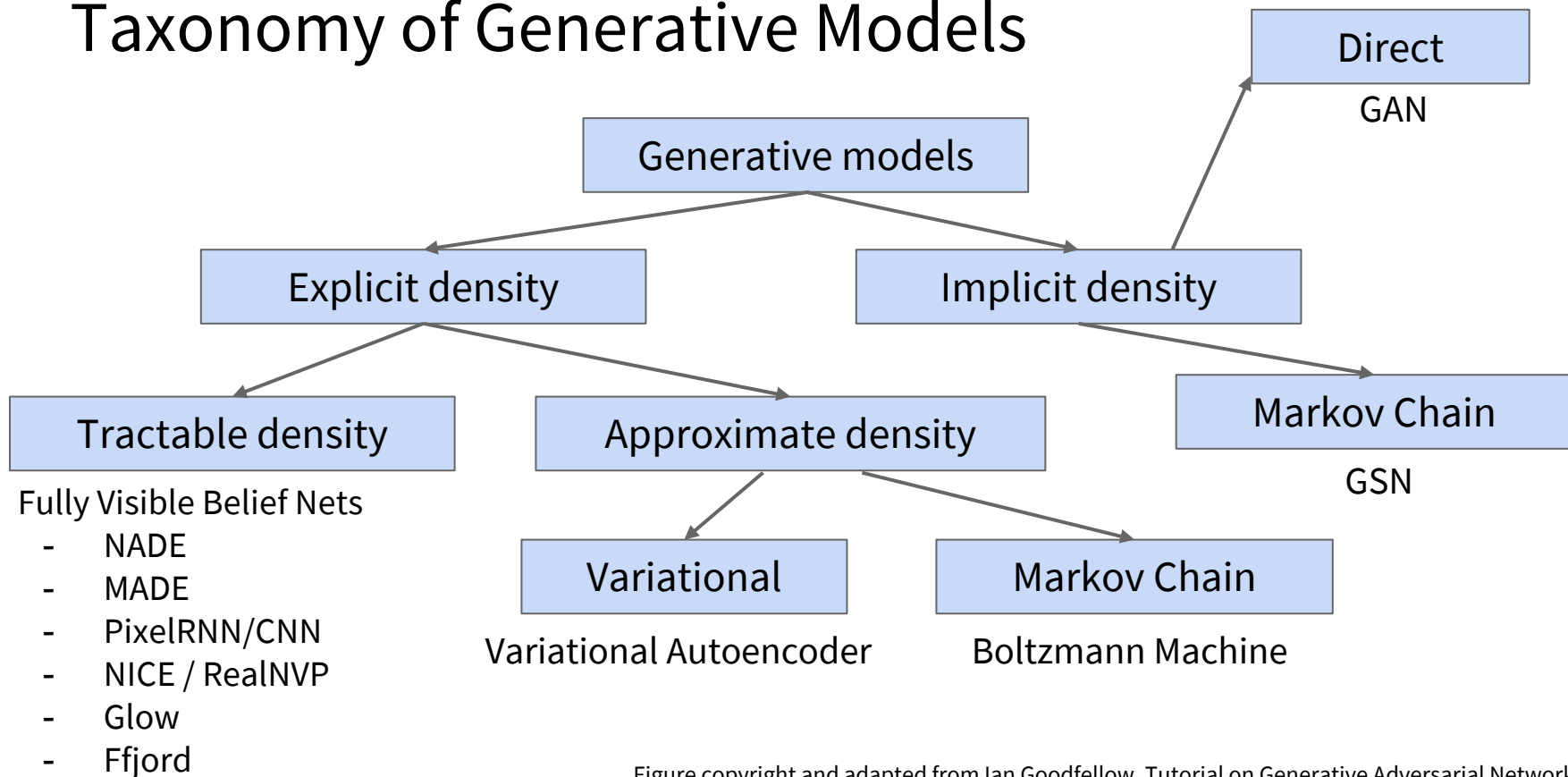

Figure copyright and adapted from Ian Goodfellow, Tutorial on Generative Adversarial Networks, 2017.

Taxonomy of Generative Models

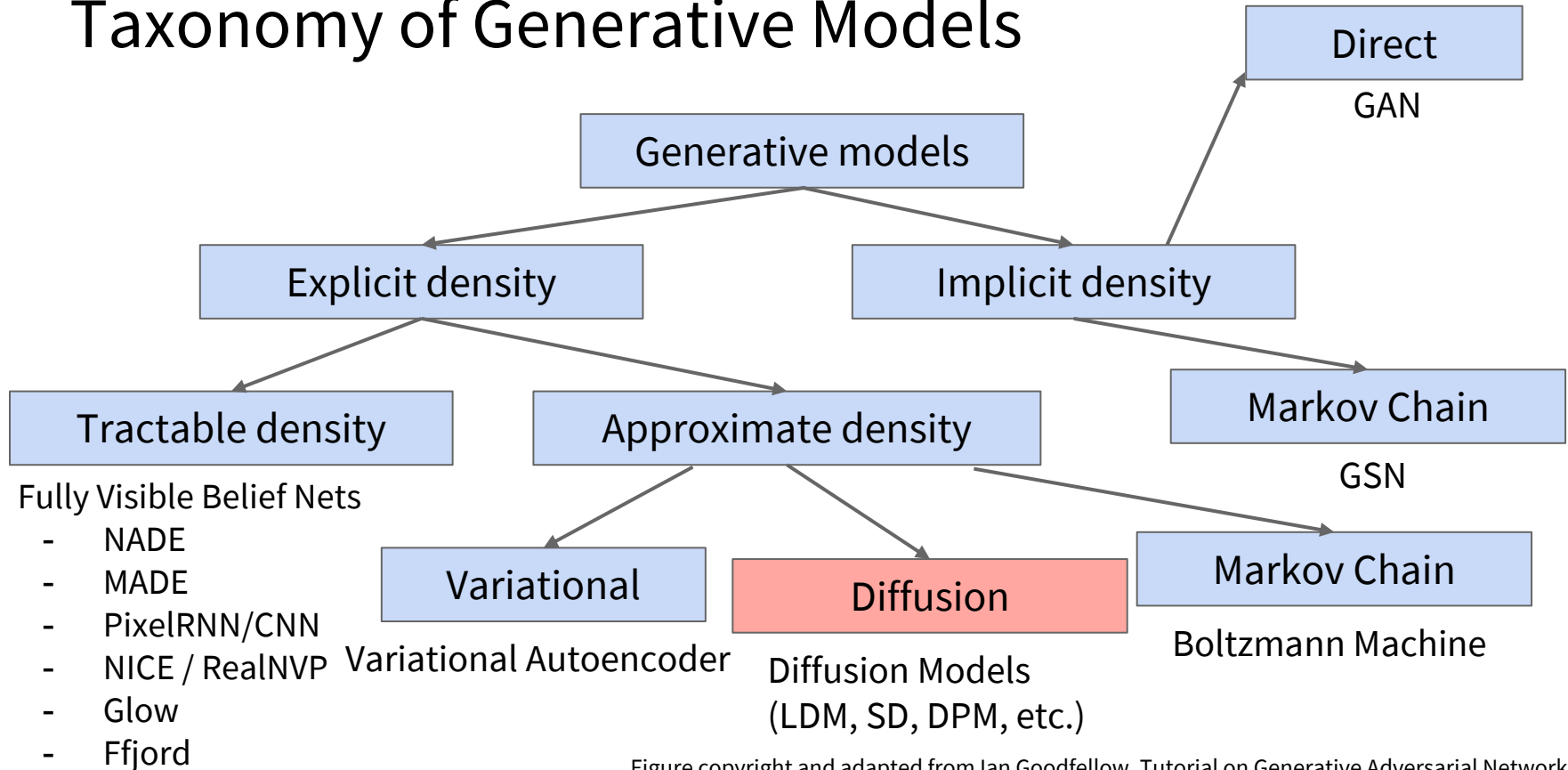

Figure copyright and adapted from Ian Goodfellow, Tutorial on Generative Adversarial Networks, 2017.

Denoising Diffusion Models

Learning to generate by denoising

Denoising diffusion models consist of two processes:

- Forward diffusion process that gradually adds noise to input
- Reverse denoising process that learns to generate data by denoising

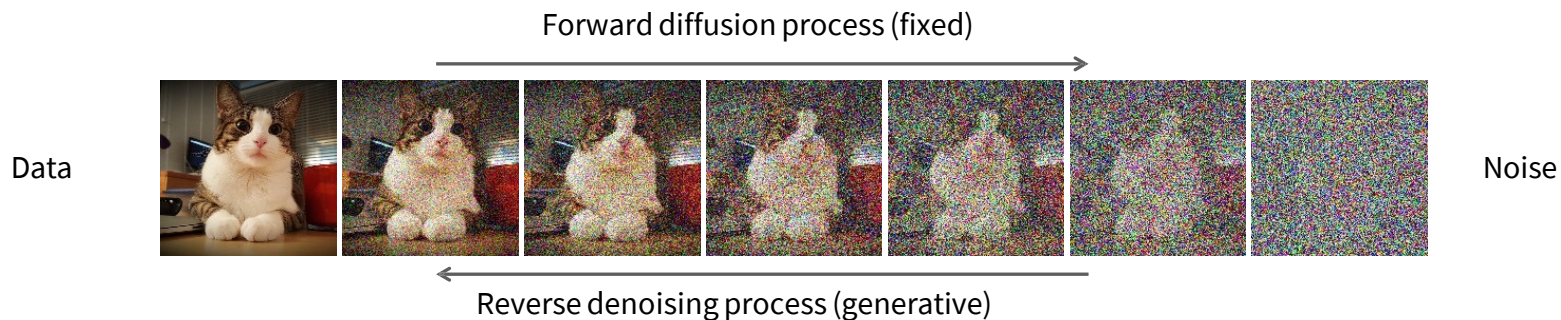

[Sohl-Dickstein et al., Deep Unsupervised Learning using Nonequilibrium Thermodynamics, ICML 2015](#) [Ho et al., Denoising Diffusion Probabilistic Models, NeurIPS 2020](#)
[Song et al., Score-Based Generative Modeling through Stochastic Differential Equations, ICLR 2021](#)

slide from <https://cvpr2022-tutorial-diffusion-models.github.io/>
Courtesy of Ruiqi Gao

2022 / 2023 : The year of diffusion and generative modeling?



Parti
Pathways Autoregressive Text-to-Image Model

Imagen Video

DALL·E 2

Stable Diffusion

Slide courtesy of Ruiqi Gao

Generative vs. Self-supervised Learning



Left: Drawing of a dollar bill from memory. Right: Drawing subsequently made with a dollar bill present. Image source: [Epstein, 2016](#)

Learning to generate pixel-level details is often unnecessary; learn high-level semantic features with pretext tasks instead (self-supervised learning)

Source: [Anand, 2020](#)

Useful Resources on Generative Models

CS 236: [Deep Generative Models](#) (Stanford)

CS 294-158 [Deep Unsupervised Learning](#) (Berkeley)

Next: Vision & Language – OpenAI Sora